

Department of Mathematics

The Ohio State University

2013-2014 Mathematics Courses

| Course Number | Course Title |
|----------------------|---|
| 1050 | Precollege Mathematics I |
| 1060 | Supplementary Pre-College Mathematics |
| 1075 | Precollege Mathematics II |
| 1116 | Excursions in Mathematics |
| 1118 | Mathematics for Architects |
| 1125 | Mathematics for Elementary Teachers I |
| 1126 | Mathematics for Elementary Teachers II |
| 1130 | College Algebra for Business |
| 1131 | Calculus for Business |
| 1148 | College Algebra |
| 1149 | Trigonometry |
| 1150 | Pre-Calculus |
| 1151 | Calculus I |
| 1152 | Calculus II |
| 1156 | Calculus for the Biological Sciences |
| 1157 | Mathematical Modeling for the Biological Sciences |
| 1161.01 | Accelerated Calculus I |
| 1161.02 | Accelerated Calculus I for Honors Engineers |
| 1165 | Math for Middle School Teachers I |
| 1166 | Math for Middle School Teachers II |
| 1172 | Engineering Mathematics A |
| 1181H | Honors Calculus I |
| 1187H | Honors Problem Solving |
| 1295# | Introductory Seminar |
| 2153 | Calculus III |
| 2162.01 | Accelerated Calculus II |
| 2162.02 | Accelerated Calculus II for Honors Engineers |
| 2167 | Calculus for Middle School Teachers |
| 2168 | History of Mathematics for Middle School Teachers |
| 2173 | Engineering Mathematics B |
| 2174 | Linear Algebra & Differ. Equations for Engineers |
| 2177 | Mathematical Topics for Engineers |
| 2182H | Honors Calculus II |

| Course Number | Course Title |
|----------------------|---|
| 2255 | Differential Equations and Their Applications |
| 2366 | Introduction to Discrete Mathematics |
| 2415 | Ordinary and Partial Differential Equations |
| 2568 | Linear Algebra |
| 3345 | Foundations of Higher Mathematics |
| 3350 | Introduction to Mathematical Biology |
| 3532 | Mathematical Foundations of Actuarial Science |
| 3588 | Practicum in Actuarial Science |
| 3589 | Introduction to Financial Mathematics |
| 3607 | Beginning Scientific Computing |
| 3618 | Theory of Interest |
| 4181H | Honors Analysis I |
| 4182H | Honors Analysis II |
| 4504 | History of Mathematics |
| 4507 | Geometry |
| 4512 | Partial Differential Equations for Science & Eng. |
| 4530 | Probability |
| 4545 | Analysis Overview |
| 4547 | Introductory Analysis I |
| 4548 | Introductory Analysis II |
| 4551 | Vector Analysis |
| 4552 | Complex Analysis |
| 4556 | Dynamical Systems |
| 4557 | Partial Differential Equations |
| 4568 | Linear Algebra for Engineering Graduate Students |
| 4573 | Elementary Number Theory |
| 4575 | Combinatorial Mathematics |
| 4578 | Discrete Mathematical Models |
| 4580 | Abstract Algebra I |
| 4581 | Abstract Algebra II |
| 5520H | Honors Linear Algebra and Differential Equations |
| 5522H | Honors Complex Analysis |
| 5529H | Honors Combinatorics |
| 5530H | Honors Probability |
| 5540H | Honors Differential Geometry |
| 5576H | Honors Number Theory |
| 5590H | Honors Abstract Algebra I |
| 5591H | Honors Abstract Algebra II |
| 5630 | Life Contingencies I |
| 5631 | Life Contingencies II |

| Course Number | Course Title |
|--------------------------|-----------------------------------|
| 5632 | Financial Economics for Actuaries |
| 5633 | Loss Models I |
| 5634 | Loss Models II |

Catalog Description:

Fractions and decimals, basic algebra, graphing lines, factoring, systems of equations.

Prerequisite:

Math Placement Level T; or Math 1040 or 40 or 50; or permission of department.

Exclusions: Not open to students with credit for any higher numbered math class, or for any quarter math class numbered higher than 50.

Purpose of Course:

Mathematics 1050 is designed to meet the needs of the students entering The Ohio State University at the lowest placement, course code T. This course will prepare students for Math 1075. Math 1050 credit will not count toward graduation in any degree program.

Follow-up Course:

Math 1075

Sequencing Chart:

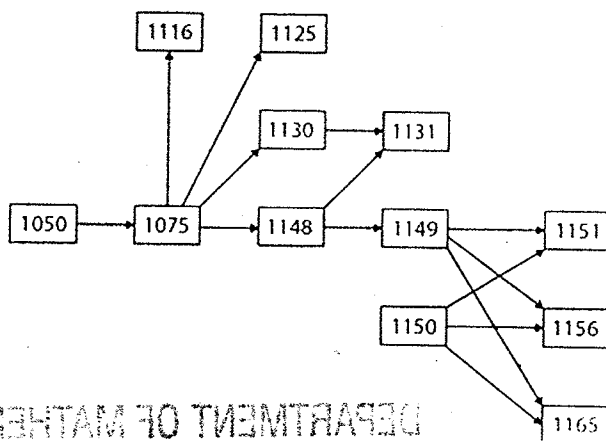

DEPARTMENT OF MATHEMATICS
THE OHIO STATE UNIVERSITY
381 WEST EIGHTEENTH AVENUE
COLUMBUS, OHIO 43210-1174

Text:

Beginning Algebra, 8th custom OSU edition, by Aufmann/Lockwood, publisher Cengage,
ISBN=9781285101279

Topics List:

1. Review: real numbers, number line, integral exponents, scientific notation, negative numbers, fractions, order of operations, basic geometry.
2. Linear equations and inequalities in one variable. Applications: word problems.
3. Graphical representations, straight lines as graphs, slope, intercepts, slope-intercept form, point-slope form. Linear inequalities in two variables.
4. Systems of two linear equations in two unknowns.
5. Polynomials: addition, subtraction, multiplication, factoring, division.
6. Solving quadratic equations by factoring. Applications.
7. Introduction to function notation.

DEPARTMENT OF MATHEMATICS
THE OHIO STATE UNIVERSITY
231 WEST EIGHTEENTH AVENUE

COLUMBUS, OHIO 43210-1174
DEPARTMENT OF MATHEMATICS
THE OHIO STATE UNIVERSITY
231 WEST EIGHTEENTH AVENUE
COLUMBUS, OHIO 43210-1174

*Primarily for Regional Campuses,
Begins SP14*

Supplementary Pre-College Mathematics

Math 1060

Math 1060 is a terminal math course designed to satisfy the Quantitative Reasoning: Basic Computation category of the General Education Requirement (GE). Students may follow-up with Math 1116 to satisfy the Quantitative Reasoning: Mathematical or Logical Analysis category of the General Education Requirement (GE). Students who wish to take further mathematics courses should take Math 1075 rather than Math 1060.

Math 1060: Supplementary Pre-College Mathematics

Catalog Description: Rational and radical expressions and equations; quadratic equations; applications.

Credits: 2

Purpose of Course: This course is only for students intending to take no further mathematics, with the possible exception of Math 1116. In particular, students intending to take Math 1075 should not take this course.

Follow-up Courses: Math 1116

Textbook: Beginning Algebra, 8th edition, by Aufmann & Lockwood, (Cengage). ISBN: 9781285101279.

Prerequisite: Math placement level S; or C- or better in 1050.

Exclusions: Not open to students with credit for any higher numbered math class, or for any quarter class numbered higher than 50.

Grading: A student's grade will be based on the student's performance on homework and exams. Homework, in total, will count for 100 points. There will be two midterms exams, worth 100 points each and a final exam, worth 200 points.

Grades will be assigned on the percentage of points received out of 500 total points.

DEPARTMENT OF MATHEMATICS
THE OHIO STATE UNIVERSITY
231 WEST EIGHTEENTH AVENUE
COLUMBUS, OHIO 43210-1174

Learning Goals:

- Recognize Rational and Radical Expressions.
- Recognize Rational, Radical and Quadratic Equations.
- Manipulate Rational and Radical Expressions using Algebra.
- Solve Equations Involving Rational and Radical Expressions.
- Solve Quadratic Equations using Algebra.
- Solve Applied Problems Involving Rational Expressions and Quadratic Equations.

Topics:

- 9.1 Multiplication and Division of Rational Expressions.
- 9.2 Expressing Fractions in Terms of the LCD.
- 9.3 Addition and Subtraction of Rational Expressions.
- 9.4 Complex Fractions.
- 9.5 Equations Containing Fractions.
- 9.6 Variation.
- 9.8 Applied Problems.

Midterm 1

- 10.1 Introduction to Radical Expressions.
- 10.2 Addition and Subtraction of Radical Expressions.
- 10.3 Multiplication and Division of Radical Expressions.
- 10.4 Solving Equations Containing Radical Expressions.

Midterm 2

- 11.1 Solving Quadratic Equations by Factoring or Taking Square Roots.
- 11.2 Solving Quadratic Equations by Completing the Square.
- 11.3 Solving Quadratic Equations Using the Quadratic Formula.
- 11.4 Complex Numbers.
- 11.6 Applied Problems.

Final Exam

DEPARTMENT OF MATHEMATICS
THE OHIO STATE UNIVERSITY
231 WEST EIGHTEENTH AVENUE
COLUMBUS, OHIO 43210-1174

DEPARTMENT OF MATHEMATICS
THE OHIO STATE UNIVERSITY
231 WEST EIGHTEENTH AVENUE
COLUMBUS, OHIO 43210-1174

Catalog Description:

Algebraic, rational, and radical expressions; functions and graphs; quadratic equations; absolute value; inequalities; and applications.

Prerequisite:

Math Placement Level S, a grade of C- or better in Math 1050, or credit for Math 75 or 1074.

Exclusions:

Not open to students with credit for any higher numbered math class, or for any quarter math class numbered higher than 75.

Text:

Beginning and Intermediate Algebra, 3rd OSU Custom Edition, Hall & Mercer, McGraw-Hill.
ISBN 9780077682194

Follow-up Courses:

- Math 1116 for students in liberal arts or students in the precertification programs on regional campuses.
- Math 1125 for students intending to pursue a M.Ed. in early or middle childhood.
- Math 1130 College Algebra for Business
- Math 1148 Traditional College Algebra

Sequencing Chart:

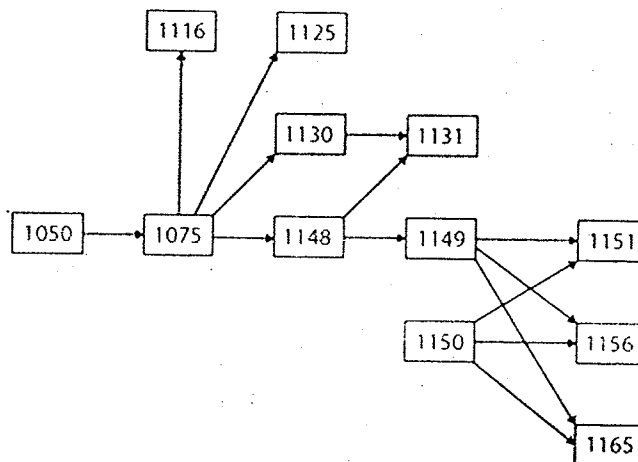

Topics List:

Ch. 4 Linear Inequalities

- 4.1 Solving linear inequalities using addition & subtraction
- 4.2 Solving linear inequalities using multiplication & division
- 4.3 Solving compound inequalities
- 4.4 Solving absolute value equations & inequalities
- 4.5 Graphing systems of inequalities in two variables

Ch. 6 Factoring Polynomials

- 6.1 Introduction to factoring polynomials
- 6.2 Factoring trinomials of the form $x^2 + bx + c$
- 6.3 Factoring trinomials of the form $ax^2 + bx + c$
- 6.4 Factoring special binomials
- 6.5 Factoring by grouping; General strategies for factoring
- 6.6 Solving equations by factoring

Ch. 9 Rational Functions

- 9.1 Graphs of rational functions
- 9.2 Reducing rational expressions; Multiplying and dividing rational expressions
- 9.3 Adding and subtracting rational expressions
- 9.4 Combining operations; Complex rational expressions
- 9.5 Solving equations containing rational expressions
- 9.6 Inverse and joint variation; other applications yielding equations with fractions

Ch. 7 Solving Quadratic Equations

- 7.1 Extraction of roots and properties of square roots
- 7.2 Solving quadratic equations by completing the square
- 7.3 The quadratic formula
- 7.4 Applications of quadratic equations
- 7.5 Complex numbers; solving quadratic equations with complex solutions

Ch. 8 Functions: Linear, Absolute Value, and Quadratic

- 8.1 Functions and representations of functions
- 8.2 Linear Functions
- 8.3 Absolute value functions
- 8.4 Quadratic functions

Ch. 10 Square Root & Cube Root Functions and Rational Exponents

- 10.1 Evaluating radical expressions
- 10.2 Adding & subtracting radical expressions
- 10.3 Multiplying & dividing radical expressions
- 10.4 Solving equations containing radical expressions
- 10.5 Rational exponents & radicals

Mathematics 1116
Sp

3 credits

Excursions in Mathematics

Catalog Description:

Critical thinking and problem solving, with relevant topics met in everyday life. Appropriate for non-science majors.

Prerequisite:

Math Placement Level R or higher; or credit for 1075, 75, 104, 1073 or 1074;
or ACT math score ≥ 22 or SAT math score ≥ 520 (scores must be less than 2 years old).

Exclusions:

Not open to students with credit for Math 1152 or higher, or for quarter math class numbered 153 or higher.

Purpose of Course:

The emphasis in this course is on intuitive understanding and developing some facility for applying mathematical ideas to problem solving.

Follow-up Courses:

None. Math 1116 is a terminal course.

Text:

Excursions in Modern Mathematics, 8th edition, by Tannenbaum, Pearson,
ISBN 9780321825735

DEPARTMENT OF MATHEMATICS
THE OHIO STATE UNIVERSITY
231 WEST EIGHTEENTH AVENUE
COLUMBUS, OHIO 43210-1174

231 WEST EIGHTEENTH AVENUE
COLUMBUS, OHIO 43210-1174

Topics List:

1. Graph theory: graphs, Euler and Hamilton circuits, algorithms for Traveling Salesman Problem, spanning trees, etc.
2. Voting & apportionment: preference ballots; apportionment paradoxes; Congressional apportionment; methods of Jefferson, Adams, and Webster.
3. Patterns & growth: Fibonacci and recursive sequences, golden ratio, population growth models: linear, exponential, and logistic.
4. Symmetry: Rigid motions, rosettes, friezes, rudiments of group theory.
5. Counting & probability: counting principles, permutations and combinations, multiplication rule, randomness, probability.
6. Fractals: recursive definitions, standard examples (Koch snowflake, Sierpinski gasket etc.), self-similarity, fractional dimension.
7. Linear programming: mixture problems, examples in low dimension, corner point principle, algorithms.

DEPARTMENT OF MATHEMATICS
THE OHIO STATE UNIVERSITY
DEPARTMENT OF MATHEMATICS
THE OHIO STATE UNIVERSITY
231 WEST EIGHTEENTH AVENUE
COLUMBUS, OHIO 43210-1174

Catalog Description:

Topics in geometry for architecture majors.

Prerequisite:

Enrollment in the School of Architecture and: Math Placement Level L or M; C- or better in 1148 or 1150; or credit for 148 or 150.

Purpose of Course:

The majority of the audience is made up of Architecture majors for whom the course is a requirement. The intent of the course is to introduce these students to the derivative and definite integral of single-variable functions, using rate of change and slope as a conceptual model for the derivative, and net change and area as a conceptual model for the definite integral. Emphasis will be placed on using these concepts to model and solve problems in the physical world. Algebraic, graphical, and tabular representations of these ideas will be used.

Follow-up Courses:

There are really no follow-up courses. To start any other mathematics sequence will probably involve beginning at an appropriate entry level course. Students interested in further course work in mathematics should consult the Mathematics Advisors in 250 Mathematics Bldg.

Text:

Course Notes, by Snapp

Topics List:

1. Geometric models, transformations, matrices.
2. Plane tessellations, concepts of symmetry.
3. Polyhedra: Platonic and Archimedean.
4. Invariants: area, volume, Euler characteristic.
5. Mathematics of perspective drawing.
6. String art: curves defined as envelopes of tangent lines, ruled surfaces.
7. Discrete curvature: Descartes theorem and beyond.
8. Higher dimensions: tesseracts and other 4-D polyhedra.

Mathematics 1125**5 credits****Mathematics for
Elementary Teachers I****Au, Sp****Currently taught in either lecture/recitation or workshop format.***Catalog Description:**

Math 1125 involves numbers, operations, geometry, measurement, and mathematical reasoning for prospective elementary school teachers.

Prerequisite:

A grade of C- or above in 1075; or credit for 1074, 75, or 104; or Math Placement Level R or above; or ACT math score ≥ 22 or SAT math score ≥ 520 (scores must be less than 2 years old) and enrollment in Early Childhood or Special Education major, or in Middle Childhood major or pre-major with area of concentration different than Math.

Exclusions:

Not open to students with credit for 106.

Purpose of Course:

To develop an appreciation of, and basic competency in, the use of analytical thought in the development of a cohesive body of useful mathematical knowledge, with special emphasis on topics encountered in elementary and middle school mathematics programs. Math 1125 deals with whole numbers, integers, rational numbers, and operations with these as well as introducing length, area, volume, angle, Euclidean geometry, symmetry and rigid motion, and knowledge of general spatial skills. *Appropriate only for those preparing to become early childhood educators and for those preparing to teach subjects other than math in middle school.*

Follow-up Courses:

Math 1126.

Text:

Mathematics for Elementary Teachers, with Activity Manual, 4th Edition, by Sybilla Beckmann, Pearson, ISBN for the package is 9780321836715 (loose-leaf).

Student Packet.

Mathematics 1125

5 credits

Mathematics for
Elementary Teachers I

Au, Sp

**Currently taught in either lecture/recitation or workshop format.*

Topics List:

1. The decimal system.
2. Fractions.
3. Addition and subtraction of fractions, decimals, and integers.
4. Multiplication of fractions, decimals, and integers.
5. Division of fractions, decimals, and integers.
6. Combining multiplication and division: proportional reasoning.
7. Measurement: meaning of length, area, and volume, unit conversion, measurement techniques, and actions preserving area/volume.
8. Rigid motions, tessellations, symmetry, constructions with various tools.
9. Problem solving (a theme throughout the course).

DEPARTMENT OF MATHEMATICS
THE OHIO STATE UNIVERSITY
231 WEST EIGHTEENTH AVENUE
COLUMBUS, OHIO 43210-1174

DEPARTMENT OF MATHEMATICS
THE OHIO STATE UNIVERSITY
231 WEST EIGHTEENTH AVENUE
COLUMBUS, OHIO 43210-1174

Mathematics 1126

5 credits

**Mathematics for
Elementary Teachers II**

Sp, Au

**Currently taught in either lecture/recitation or workshop format.*

Catalog Description:

Continuation of 1125: Math 1126 involves geometry, measurement, number theory, algebraic thinking, counting techniques, probability, a mathematical reasoning for prospective elementary school teachers.

Prerequisite:

A grade of C- or above in 1125; and enrollment in Early Childhood or Special Education major, or in Middle Childhood major or pre-major with area of concentration different than Math.

Exclusions:

Not open to students with credit for 107.

Purpose of Course:

To develop an appreciation of, and basic competency in, the use of analytical thought in the development of a cohesive body of useful mathematical knowledge, with special emphasis on topics encountered in elementary and middle school mathematics programs. Math 1126 includes counting techniques and probability, basic geometric concepts and measurement, symmetry and rigid motions, congruence, similarity and scaling, coordinate geometry, algebraic thinking, equations, and functions. *Appropriate for those preparing to become early childhood educators and for those preparing to teach subjects other than math in middle school.*

Text:

Autumn 2013:

Mathematics for Elementary Teachers, with Activity Manual, 3rd Edition, by Sybilla Beckmann, Pearson.

and

Student Packet.

Spring 2014:

Mathematics for Elementary Teachers, with Activity Manual, 4rd Edition, by Sybilla Beckmann, Pearson, ISBN for the package is 9780321836715 (loose-leaf).

and

Student Packet.

Topics List:

1. Algebraic thinking: expressions, measurement formulas, scaling, functions, use of formulas, graphs, and tables, sequences and series, and coordinate geometry.
2. Number theory: factors and multiples, LCM, GCF, divisibility tests, prime numbers, unique factorization, notations for fractions and decimals.
3. Counting: inclusion/exclusion, fundamental counting principle, tree diagrams, permutations and combinations, Pascal's triangle.
4. Basic ideas of probability: Law of Large Numbers, sample and event spaces, use of tree diagrams, simulations, and discussion of common misconceptions.
5. Geometric constructions: compass and straightedge.
6. Deductive proofs.
7. Problem solving (a theme throughout the course).

DEPARTMENT OF MATHEMATICS
THE OHIO STATE UNIVERSITY
231 WEST EIGHTEENTH AVENUE
COLUMBUS, OHIO 43210-1174

Catalog Description:

Algebraic, exponential, and logarithmic functions. Matrix algebra. Applications to business.

Prerequisite:

Math Placement Level N; C- or better in 1075; or credit for 104; or ACT math score ≥ 22 or SAT math score ≥ 520 (scores must be less than 2 years old).

Exclusions:

Not open to students with credit for 1131 or for any math course numbered 1149 or higher, or a quarter-system math course numbered 150 or higher.

Purpose of Course:

Math 1130 is a pre-calculus course with a finance section slanted toward a business program. The applications are business related.

Follow-up Course:

Math 1131

Text:

Introductory Mathematical Analysis for Business, Economics, and the Life and Social Sciences, 13th Edition; by Haeussler, Paul, and Wood; published by Pearson; ISBN 9781256966096

Topics List:

Review of Algebra:

- 0.7: Equations, In Particular Linear Equations.
- 0.8: Quadratic Equations.
- 1.2: Linear Inequalities.
- 1.3: Applications of Inequalities.
- 1.6: Sequences

Functions:

- 2.1: Functions.
- 2.2: Special functions.
- 2.3: Combinations of functions.
- 2.4: Inverse Functions.
- 2.5: Graphs of functions

3. Linear and Quadratic Functions:

- 3.1: Lines
- 3.2: Applications and Linear Functions.
- 3.3: Quadratic Functions
- 3.4: Systems of Linear Equations.
- 3.6: Applications of Systems of Equations.

4. Exponential and Logarithmic Functions:

- 4.1: Exponential Functions.
- 4.2: Logarithmic functions.
- 4.3: Properties of Logarithms.
- 4.4: Logarithmic and Exponential Equations.

5. Mathematics of Finance:

- 5.1: Compound Interest.
- 5.2: Present Value.
- 5.3: Interest Compounded Continuously.
- 5.4: Annuities
- 5.5: Amortization of Loans.

6. Matrix Algebra:

- 6.1: Matrices.
- 6.2: Matrix Addition and Scalar Multiplication.
- 6.3: Matrix Multiplication.
- 6.4: Solving Systems by Reducing Matrices.
- 6.6: Inverses

Catalog Description:

Survey of calculus of one and several variables; applications to business.

Prerequisite:

Math Placement Level L; C- or better in 1130, 1148, 1144, or 1150; credit for 130 or 148.

Exclusions:

Not open to students with credit for a math course numbered 1151 (151.xx) or higher, or for 132 or 1134.

Text:

Introductory Mathematical Analysis for Business, Economics, and the Life and Social Sciences, 13th Edition, by Haeussler, Paul, Wood, published by Pearson: ISBN-10: 1-256-96609-6, ISBN-13: 978-1-256-96609-8.

Topics List:

1. Idea of limits, continuity, and derivative. Interpret derivative as a limit, slope, and rate of change.
2. Calculate derivatives of algebraic, exponential, and logarithmic functions.
3. Monotonicity, concavity, extrema of functions, second derivative tests, applications to graphing.
4. Applications: marginal analysis in business, optimization.
5. Anti-derivatives, separable first-order ODEs.
6. Riemann integral, substitution, Fundamental Theorem, area, applications.
7. Partial derivatives, extrema and second derivative test for two-variable functions, Lagrange multipliers. Applications to business.

DEPARTMENT OF MATHEMATICS
THE OHIO STATE UNIVERSITY
231 WEST EIGHTEENTH AVENUE
COLUMBUS, OHIO 43210-1174

DeVol Bevilacqua, Diana

From: McNeal, Betsy
Sent: Tuesday, February 25, 2014 1:10 PM
To: DeVol Bevilacqua, Diana
Subject: RE: math 1135 and 1136

AU 14 start

Dear Diana,
Here are some answers for Ginny and any other advisor who is trying to update her/himself! The main point is that the 1135/1136/2137/2138 is a block of courses that cannot be split up, and that 1135/1136 CAN be selected instead of 1125/1126 because the two blocks will deal with the same material needed for all students who are currently required to take the 1125 sequence.

* 1135/36 can substitute for EC 1125/26, but cannot substitute for MC 1165/66. The content of 1165/66 is spread over the 4-course sequence 1135/36, 2137/38 (which also contains the content of 2167/68).

* Each campus has an independent choice of whether to offer program A and/or program B, or some subset of these:

- A: 1125/26, 1165/66, and 2167/68
- B: 1135/36 and 2137/38

There is no campus restriction stated in the course catalog because in principle (although not in practice) either program could be offered on any campus.

Please continue to let me know of any questions and/or concerns that arise around this! We are all learning this.

Betsy

DEPARTMENT OF MATHEMATICS
THE OHIO STATE UNIVERSITY
231 WEST EIGHTEENTH AVENUE
COLUMBUS, OHIO 43210-1174

COLUMBUS, OHIO 43210-1174

Catalog Description:

Functions: polynomial, rational, radical, exponential, and logarithmic. Introduction to right-angle trigonometry. Applications.

Prerequisite:

Math Placement Level N; C- or better in 1075; or credit for 104 or 148; or ACT math score ≥ 22 or SAT math score ≥ 520 (scores must be less than 2 years old).

Exclusions:

Not open to students with credit for 1144 or 1149 or higher, or for a quarter-system math course numbered 150 or higher.

Purpose:

College Algebra provides students a college level academic experience that emphasizes the use of algebra and functions in problem solving and modeling, where solutions to problems in real-world situations are formulated, validated, and analyzed using mental, paper-and-pencil, algebraic and technology-based techniques as appropriate using a variety of mathematical notation. Students should develop a framework of problem-solving techniques (e.g., read the problem at least twice; define variables; sketch and label a diagram; list what is given; restate the question asked; identify variables and parameters; use analytical, numerical and graphical solution methods as appropriate; determine the plausibility of and interpret solutions). – Adapted from the MAA/CUPM CRAFTY 2007 College Algebra Guidelines. This course is intended to satisfy the requirements of the Ohio Board of Regents TMM001 College Algebra course with learning outcomes specified in: <http://regents.ohio.gov/transfer/otm/otm-learning-outcomes.php>

Text:

Precalculus: Mathematics for Calculus, 6th Edition, by J.Stewart, L.Redlin, and S.Watson, published by Cengage. ISBN Loose-leaf: 9781133904489 Hardback: 9780840068077

Technology: All students are required to have a graphing calculator, TI-83 or TI-84. Note: Any calculators (including TI-89 and TI-92) that use a Computer Algebra System (CAS) are not permitted.

Sequencing Chart:

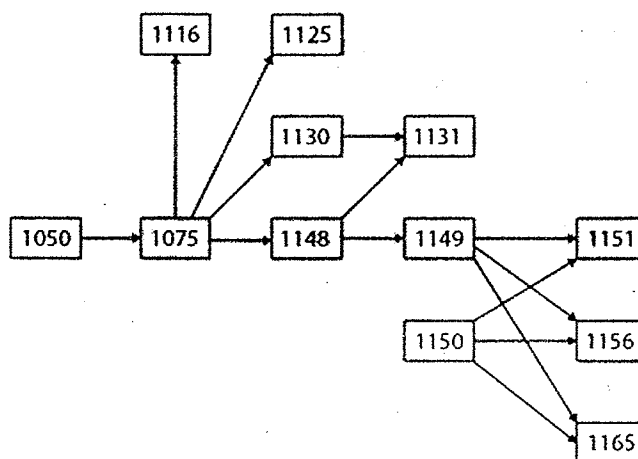

Topics List:

| | | |
|---------|---|---|
| Week 1 | Section 1.7 – Inequalities | |
| | Section 2.1 – What is a function? | <i>Ch 2 Functions</i> |
| Week 2 | Section 2.2 – Graphs of functions | |
| | Section 2.3 – Getting information from a function | |
| Week 3 | Section 2.4 – Average rate of change of a function | |
| | Section 2.5 – Transformations of functions | |
| Week 4 | Section 2.6 – Combining functions | |
| | Section 2.7 – One-to-one functions and their inverses | |
| Week 5 | Section 3.1 – Quadratic functions and models. | <i>Ch 3 Rational functions</i> |
| Week 6 | Test 1 | |
| | Section 3.2 – Polynomial functions | |
| | Section 3.3 – Dividing polynomials | |
| Week 7 | Section 3.5 – Complex Numbers | |
| | Section 3.6 – Complex Zeros | |
| Week 8 | Section 3.7 – Rational functions | |
| | Section 4.1 – Exponential functions. | <i>Ch 4 Exponentials & logarithms</i> |
| Week 9 | Section 4.2 – The natural exponential function | |
| Week 10 | Test 2 | |
| | Section 4.3 – Logarithmic functions | |
| | Section 4.4 – Laws of logarithms | |
| Week 11 | Section 4.5 – Exponential and logarithmic equations | |
| Week 12 | Section 4.6 – Modeling with exponential and logarithmic equations; applications | |
| | Test 3 | |
| | Section 10.1 – Linear systems (two variables) | <i>Ch 10 Systems of equations</i> |
| | Section 10.2 – Linear systems in several variables | |
| Week 13 | Section 6.1 – Angle measure | <i>Ch 6 Trigonometry</i> |
| | Section 6.2 – Right triangle trigonometry | |
| Week 14 | Section 6.3 – Trigonometric functions of angles | |
| | Comprehensive review, Final Exam | |

Catalog Description:

Trigonometric functions and their properties. Vectors, polar coordinates and complex numbers.

Prerequisite:

C- or better in 1148, or permission of department.

Exclusions:

Not open to students with credit for 1144, or for any math course numbered 1150 (150) or higher.

Text:

Precalculus: Mathematics for Calculus, 6th Edition, by J. Stewart, L. Redlin, and S. Watson, published by Cengage. ISBN Loose-leaf: 9781133904489 Hardback: 9780840068077

Technology:

A graphing calculator is a required component in this course. It is recommended that you use a TI-83, TI-83 plus, or a TI-84. Note that the TI-89, TI-92, and calculators that use a Computer Algebra System are not permitted.

Topics List:

- 6.1 Angle Measure
- 6.2 Trigonometry of Right Triangles
- 6.3 Trigonometric Functions of Angles
- 5.1 The Unit Circle
- 5.2 Trigonometric Functions of Real Numbers
- 5.3 Trigonometric Graphs
- 5.4 More Trigonometric Graphs
- 5.5 Inverse Trigonometric Functions and Their Graphs

Midterm 1

DEPARTMENT OF MATHEMATICS
THE OHIO STATE UNIVERSITY
231 WEST EIGHTEENTH AVENUE
COLUMBUS, OHIO 43210-1174

- 6.4 Right Triangles
- 6.5 The Law of Sines
- 6.6 The Law of *Cosines*
- 7.1 Trig. Identities
- 7.2 Addition and Subtraction Formulas
- 7.3 Double/Half Angle and Product-Sum Formulas
- 7.4 Trig. Equations
- 7.5 More Trig. Equations
- 8.3 Polar Forms of Complex Numbers; De Moivre's Theorem
- 9.1 Vectors in Two Dimensions

Midterm 2

- 9.2 The Dot Product
- 11.1 Parabolas
- 11.2 Ellipses
- 11.3 Hyperbolas

DEPARTMENT OF MATHEMATICS
THE OHIO STATE UNIVERSITY
232 WEST EIGHTEENTH AVENUE
COLUMBUS, OHIO 43210-1174

Catalog Description:

Functions: polynomial, rational, radical, exponential, logarithmic, trigonometric, and inverse trigonometric. Applications.

Prerequisite:

Math Placement Level M.

Exclusions:

Not open to students with credit for 1144, 1148, 1149, for any higher numbered math course, or for any quarter-system math course 150 or higher.

Text:

Precalculus: Mathematics for Calculus, 6th Edition, by J. Stewart, L. Redlin, and S. Watson, published by Cengage, ISBN Loose-leaf: 9781133904489 Hardback: 9780840068077

Technology:

Every student is required to have a graphing calculator comparable in capability to a TI-83 or TI-84. However, calculators with symbolic algebra capabilities are not allowed during exams or quizzes.

Topics List:

- 2.1 Functions
- 2.2 Graphs of Functions
- 2.3 Information from Graphs
- 2.4 Average Rate of Change
- 2.5 Transformations of Functions
- 2.6 Combining Functions
- 2.7 One-to-One Functions and Their Inverses
- 3.1 Quadratic Functions
- 3.2 Polynomial Functions and their Graphs
- 3.3 Dividing Polynomials (Remainder and Factor Theorems)
- 3.6 Complex Zeros and Fundamental Theorem of Algebra
- 3.7 Rational Functions

Midterm 1

- 1.7 Inequalities (Polynomial and Rational Inequalities)
- 4.1/4.2 Exponential and Natural Exponential Functions
- 4.3 Logarithmic Functions
- 4.4 Laws of Logarithms
- 4.5 Exponential and Logarithmic Equations
- 4.6 Modeling with Exponential and Logarithmic Functions
- 6.1 Angle Measure
- 6.2 Trigonometry of Right Triangles
- 6.3 Trigonometric Functions of Angles
- 5.1 The Unit Circle
- 5.2 Trigonometric Functions of Real Numbers
- 5.3 Trigonometric Graphs
- 5.4 More Trigonometric Graphs
- 5.5 Inverse Trigonometric Functions and Their Graphs
- 6.4 Right Triangles
- 6.5 The Law of Sines
- 6.6 The Law of *Cosines*

Midterm 2

- 7.1 Trig. Identities
- 7.2 Addition and Subtraction Formulas
- 7.3 Double/Half Angle and Product-Sum Formulas
- 7.4 Trig. Equations
- 7.5 More Trig. Equations
- 8.3 Polar Forms of Complex Numbers; De Moivre's Theorem
- 9.1 Vectors in Two Dimensions
- 9.2 The Dot Product
- 10.1 Systems of Linear Equations in Two Variables
- 10.2 Systems of Linear Equations in Several Variables
- 11.1 Parabolas
- 11.2 Ellipses
- 11.3 Hyperbolas

Midterm 3

- 12.1 Sequences and Summation Notation
- 12.2 Arithmetic Sequences
- 12.3 Geometric Sequences

DEPARTMENT OF MATHEMATICS
THE OHIO STATE UNIVERSITY
231 WEST EIGHTEENTH AVENUE
COLUMBUS, OHIO 43210-1174

Catalog Description:

Differential and integral calculus of one real variable.

Prerequisite:

Math Placement Level L, or C- or better in: 1150, or in both 1148 & 1149; or in 150 or 1144.

Exclusions:

Not open to students with credit for any higher numbered math class.

Text:

Calculus for Scientists and Engineers: Early Transcendentals, by W. Briggs, L. Cochran, and B. Gillett, published by Pearson. ISBN: 1256776467

Topics List:

- 1.3 Inverse, Exponential, and Logarithmic Functions
- 1.4 Trigonometric Functions and Their Inverses
- 2.1 The Idea of Limits
- 2.2 Definitions of Limits
- 2.3 Techniques for Computing Limits
- 2.4 Infinite Limits
- 2.5 Limits at Infinity
- 2.6 Continuity

Midterm 1

- 3.1 Introducing the Derivative
- 3.2 Rules of Differentiation
- 3.3 The Product and Quotient Rules
- 3.4 Derivatives of Trigonometric Functions
- 3.5 Derivative as Rates of Change
- 3.6 The Chain Rule
- 3.7 Implicit Differentiation
- 3.8 Derivatives of Logarithmic and Exponential Functions
- 3.9 Derivatives of Inverse Trigonometric Functions
- 3.10 Related Rates
- 4.1 Maxima and Minima
- 4.2 What Derivatives Tell Us

Midterm 2

- 4.3 Graphing Functions
- 4.4 Optimization Problems
- 4.5 Linear Approximations and Differentials
- 4.6 Mean Value Theorem
- 4.7 L'Hospital's Rule
- 4.8 Newton's Method
- 4.9 Antiderivatives
- 5.1 Approximating Areas under Curves

Midterm 3

- 5.2 Definite Integrals
- 5.3 Fundamental Theorem of Calculus
- 5.4 Working with Integrals
- 5.5 Substitution Rule
- 6.1 Velocity and Net Change

Final

DEPARTMENT OF MATHEMATICS
THE OHIO STATE UNIVERSITY
231 WEST EIGHTEENTH AVENUE
COLUMBUS, OHIO 43210-1174

Catalog Description:

Integral calculus, sequences and series, parametric curves, polar coordinates, vectors.

Prerequisite:

C- or better in 1151, 1156, 152.xx, 161.xx or 161.01H; or 114 or 1114.

Exclusions:

Not open to students with credit for any higher numbered math class or with credit for quarter-system Math courses numbered 153.xx or above.

Text:

Calculus for Scientists and Engineers: Early Transcendentals, 1st OSU custom edition, by Briggs, Cochran, Gillett, published by Pearson, ISBN: Looseleaf/Full Bk: 978125678771X, Hardcover/Full Bk: 9781256776467.

Topics List:

1. Regions between Curves
2. Volume by Slicing, Volume by Shells
3. Lengths of Curves
4. Physical Applications
5. Exponential Models
6. Basic Approaches to Integration
7. Integration by Parts
8. Trigonometric Integrals
9. Trig Substitution
10. Partial Fractions
11. Improper Integrals
12. Basic Ideas of Differential Equations
13. Differential Fields and Euler's Method
14. Separable Differential Equations
15. Sequences

Cont.

Page 1

DEPARTMENT OF MATHEMATICS
THE OHIO STATE UNIVERSITY
384 WEST EIGHTEENTH AVENUE
COLUMBUS, OHIO 43210-1174
DEPARTMENT OF MATHEMATICS
THE OHIO STATE UNIVERSITY
231 WEST EIGHTEENTH AVENUE
COLUMBUS, OHIO 43210-1174

Math 1152
Course Coordinator: D. McGinnis
2013-2014

16. Series
17. Divergence and Integral Tests
18. Ratio and Root Tests
19. Comparison Tests
20. Alternating Series
21. Approximate Functions with Polynomials
22. Properties of Power Series
23. Taylor Series
24. Parametric Equations
25. Polar Equations
26. Calculus in Polar Coordinates
27. Conic Sections (Conic Sections in Polar optional)
28. Vectors in the Plane and 3-space (optional)
29. Dot Products (optional)
30. Cross Products (optional)
31. Lines and Curves in Space (optional)

**DEPARTMENT OF MATHEMATICS
THE OHIO STATE UNIVERSITY
231 WEST EIGHTEENTH AVENUE
COLUMBUS, OHIO 43210-1174**

DEPARTMENT OF MATHEMATICS
THE OHIO STATE UNIVERSITY
231 WEST EIGHTEENTH AVENUE
COLUMBUS, OHIO 43210-1174

Catalog Description:

Limits, continuity, derivatives, mean value theorem, extrema, curve sketching, related rates, differentiation of the trig, log, and exponential functions, basic integration techniques, with particular motivations from and application to the Biological Sciences.

Prerequisite:

A grade of C- or above in 1148 and 1149, or a grade of C- or above in 1150, or credit for 150, or Math Placement Level L. Not open to students with credit for 1151 (151.xx) or above. GE quant reason math and logical any course.

Exclusions:

Not open to students with credit for 1151, or with credit for any higher numbered math class.

Purpose of Course:

To provide students with a solid foundation in one-variable differential calculus, to model and analyze phenomena in the Biological Sciences.

Follow-up Course:

Math 1157

Text:

Calculus for Biology and Medicine, 3rd Edition, by Claudia Neuhauser, Pearson, ISBN 9780321644688

DEPARTMENT OF MATHEMATICS
THE OHIO STATE UNIVERSITY
231 WEST EIGHTEENTH AVENUE
COLUMBUS, OHIO 43210-1174

Topics List:

- 1.2 Elementary Functions
 - 1.3/2.1 Graphing/Exponential Growth and Decay
 - 2.2 Sequences
 - 3.1-3.4 Limits and Continuity
 - 3.5 Properties of Continuous Functions
 - 4.1 Derivatives
 - 4.2-4.3 Rules of Differentiation, Product and Quotient Rules
 - 4.4 Chain Rule and Higher Derivatives
 - 4.5-4.7 Derivatives of Special Functions and Inverse Functions
 - 5.1-5.3 Extrema, Mean Value Theorem, Monotonicity, Concavity, Inflection Points
 - 5.4 Optimization
 - 5.5 L'Hospital's Rule
 - 5.8 Antiderivatives
 - 6.1 The Definite Integral
 - 6.2 The Fundamental Theorem of Calculus
 - 6.3 Applications of Integration
 - 7.1-7.2 Integration Techniques
- Also: Small-group Projects

DEPARTMENT OF MATHEMATICS
THE OHIO STATE UNIVERSITY
231 WEST EIGHTEENTH AVENUE
COLUMBUS, OHIO 43210-1174

Mathematics 1157
Sp

5 credits

Mathematical Modeling
for the Biological Sciences

Catalog Description:

Models in life sciences using multivariable calculus, linear algebra, dynamical systems, and ordinary differential equations.

Prerequisite:

C- or better in: 1156, 1151, 1161.xx or 1181H; or credit for 152.xx.

Exclusions:

Not open to students with credit for 1152 or with credit for any higher numbered math class.

Purpose of Course:

To provide students with a solid foundation in one-variable calculus, to model and analyze phenomena in the life sciences.

Text:

Calculus for Biology and Medicine, 3rd Edition, by Claudia Neuhauser, Pearson, ISBN 9780321644688

DEPARTMENT OF MATHEMATICS
THE OHIO STATE UNIVERSITY
231 WEST EIGHTEENTH AVENUE
COLUMBUS, OHIO 43210-1174

Topics List:

- 7.3 Rational Functions and Partial Fractions
 - 7.5 Numerical Integration
 - 7.6 Taylor Approximation
 - 8.1 Solving Differential Equations
 - 8.2 Equilibria and Their Stability
 - 9.1-9.2 Linear Systems and Matrices
 - 9.3 Linear Maps, Eigenvectors, and Eigenvalues
 - 10.3 Multivariable functions & Partial Derivatives
 - 10.4 Tangent Planes, Differentiability, and Linearization
 - 11.1-11.2 Linear Systems: Theory and Applications
 - 11.3-11.4 Nonlinear Autonomous Systems: Theory and Applications
- Also: Small-group Projects
Markov Chains

DEPARTMENT OF MATHEMATICS
THE OHIO STATE UNIVERSITY
231 WEST EIGHTEENTH AVENUE
COLUMBUS, OHIO 43210-1174

Mathematics 1161.01
Mathematics 1161.02
Au

5 credits each

Accelerated Calculus I
Accelerated Calculus I for
Honors Engineers

Catalog Description:

Differential and integral calculus of one real variable.

Prerequisites:

Math Placement Level L and previous calculus experience.

Exclusions:

For 1161.01: Not open to students with credit for any math course numbered 1152 or higher, or for the quarter-system math courses 151.xx and 152.xx, or for any quarter-system course numbered 162.xx or higher.

For 1161.02: Intended for students in Freshman Engineering Honors.

Text:

Calculus for Scientists and Engineers: Early Transcendentals, 1st OSU custom edition, by Briggs, Cochran, Gillett, Person, ISBN: Loose-leaf/Full Bk: 978125678771X, Hardcover/Full Bk: 9781256776467

Topics:

- 2.1; 2.2 The Idea of Limits; Definition of Limits
- 2.2; 2.3 Definition of Limits; Limit Laws
- 2.4; 2.5 Infinite Limits; Limits at Infinity
- 2.5; 2.6 Limits at Infinity; Continuity, the Intermediate Value Theorem
- 2.7 Precise Definition of Limits
- 3.1 Introducing the Derivative
- 3.2; 3.3 Rules of Differentiation; Product and Quotient Rules
- 3.4; 3.5 Derivatives of Trig Functions; Derivatives as Rate of Change
- 3.5; 3.6 Derivatives as Rate of Change; The Chain Rule
- 3.7 Implicit Differentiation

Midterm 1

DEPARTMENT OF MATHEMATICS
THE OHIO STATE UNIVERSITY
231 WEST EIGHTEENTH AVENUE
COLUMBUS, OHIO 43210-1174

Mathematics 1161.01
Mathematics 1161.02
Au

5 credits each

Accelerated Calculus I
Accelerated Calculus I for
Honors Engineers

- 3.8; 3.9 Derivatives of Logarithms and Exponential Functions; Derivatives of Inverse Functions
3.10 Related Rates
4.1 Maxima and Minima
4.2; 4.3 What derivatives Tell Us; Graphing
4.4 Optimization Problems
4.5; 4.6 Linear Approximations and Differentials; Mean Value Theorem
4.6; 4.7 Mean Value Theorem; L'Hopital's Rule
4.9 Antiderivatives
5.1 Approximating Areas under Curves, Sigma Notation
5.2 Definite Integrals

Midterm 2

- 5.3 Fundamental Theorem of Calculus
5.4; 5.5 Working with Integrals; Substitution Rule
5.5; 6.1 Substitution Rule; Velocity and Net Change
6.2 Regions between Curves
6.3 Volumes by Slicing
6.4 Volumes by Shells
6.5; 6.6 11.5 Lengths of Curves; Surface Area
6.7 Physical Applications: Density & Mass, Work, Lifting Problems, Force & Pressure
6.8; 6.9 Log and Exponential Functions Again; Exponential Growth and Decay
7.1; 7.2 Integration: Basic Approaches; Integration by Parts

Midterm 3

- 7.3 Trig Integrals
7.4 Trig Substitutions
7.5 Partial Fractions
7.8 Improper Integrals

Final

DEPARTMENT OF MATHEMATICS
THE OHIO STATE UNIVERSITY
231 WEST EIGHTEENTH AVENUE
COLUMBUS, OHIO 43210-1174

Catalog Description:

Algebra and reasoning for middle school teachers.

Prerequisite:

A grade of C- or above in 1148 and 1149, or grade of C- or above in 1150, or credit for 150, or Math Placement Level L; and enrollment in Middle Childhood Education major within either College of Arts and Sciences or College of Education and Human Ecology with Math as an Area of Concentration.

Purpose of Course:

The purpose of the course is to prepare teachers of middle school students. In particular, it intends to deepen and extend the prospective teachers' content knowledge of the mathematics they will teach as well as their ability to reason with and communicate that knowledge.

Follow-up Courses:

Math 1166, Math 2167, and Math 2168

Text:

Course Notes, by B. Snapp

Recommended Text: Algebra Connections, by Papick, published by Pearson, ISBN 9780131449282

Topics List:

1. Number systems (whole, integer, rational, real): uses, notations (including place value), and comparison of size. Addition and Subtraction
2. Division algorithm, Euclidean algorithm, Diophantine equations, counting techniques.
3. Algebra: polynomials, their structure and arithmetic, division algorithm.
4. Solving equations: linear, quadratic, etc., using complex numbers.
5. Introduction to mathematical induction.
6. Applications: modeling real-world topics.
7. Problem solving (a theme throughout the course).

DEPARTMENT OF MATHEMATICS
THE OHIO STATE UNIVERSITY
231 WEST EIGHTEENTH AVENUE
COLUMBUS, OHIO 43210-1174

Catalog Description:

Geometry for middle school teachers.

Purpose of Course:

The purpose of the course is to prepare teachers of middle school students. In particular, it intends to deepen and extend the prospective teachers' content knowledge of the mathematics they will teach as well as their ability to reason with and communicate that knowledge.

Prerequisite:

C- or better in 1165, and enrollment in Middle Childhood Education major with Math as an Area of Concentration.

Follow-up Courses:

Math 2167 and Math 2168

Text:

Course Notes.

Topics List:

1. Visual reasoning via "proofs without words." Measurement (also teaching measurement in middle school)
2. Geometric constructions, congruence, similarity, and problem solving.
3. Coordinate geometry with emphasis on solving equations.
4. Non-Euclidean geometries.
5. Geometric transformations coordinate geometry, complex numbers.
6. Scaling and relationship between perimeter and area.
7. Measurement issues.
8. Modeling real-world situations.

DEPARTMENT OF MATHEMATICS
THE OHIO STATE UNIVERSITY
231 WEST EIGHTEENTH AVENUE
COLUMBUS, OHIO 43210-1174

Catalog Description:

Techniques of integration, Taylor series, differential calculus of several variables.

Prerequisites:

C- or better in 1151, 152.xx, 1156, 1161.xx, 161.01H, 161.xx, 1114 or 114.

Exclusions:

Not open to students in math, pre-actuarial science, or actuarial science. Not open to students with credit for any higher numbered math class, or for 1152; or for 254.xx or higher numbered math class.

Text:

Calculus for Scientists and Engineers: Early Transcendentals, 1st OSU custom edition, by Briggs, Cochran, Gillett, published by Pearson,
ISBN: Loose-leaf/Full Bk: 978125678771X, Hardcover/Full Bk: 9781256776467

Topics:

- 6.2 Regions between Curves
- 6.3 Volume by Slicing
- 6.4 Volume by Shells
- 6.5 Lengths of Curves
- 6.7 Physical Applications
- 7.1 Basic Approaches to Integration
- 7.2 Integration by Parts
- 7.3 Trigonometric Integrals

Midterm 1

DEPARTMENT OF MATHEMATICS
THE OHIO STATE UNIVERSITY
231 WEST EIGHTEENTH AVENUE
COLUMBUS, OHIO 43210-1174

- 7.4 Trig Substitution
- 7.5 Partial Fractions
- 7.8 Improper Integrals
- 9.1 Overview of Sequences and Series
- 9.2 Sequences
- 9.3 Series (and Idea of Convergence)
- 9.4 Divergence Test (and Properties of Convergent Series only)
- 9.5 Ratio Test (only)
- 10.1 Approx functions with Polynomials
- 10.2 Properties of Power Series
- 10.3, 10.4 Taylor Series

Midterm 2

- 11.1 Parametric Equations
- 11.2 Polar Equations
- 11.3 Calculus in Polar Coordinates
- 11.4 Conic Sections (Conic Sections in Polar optional)
- 12.1, 12.2 Vectors in the Plane and 3-Space
- 12.3, 12.4 Dot Products, Cross Products
- 12.5 Lines and Curves in Space
- 12.6 Calculus of Vector-Valued Functions
- 12.7 Motion in Space
- 12.8 Lengths of Curves

Midterm 3

- 13.1 Planes and Surfaces
- 13.2 Graphs and Level Curves
- 13.3 Limits and Continuity
- 13.4 Partial Derivatives
- 13.5 The Chain Rule
- 13.6 Directional Derivatives, Gradient

Final

DEPARTMENT OF MATHEMATICS
THE OHIO STATE UNIVERSITY
231 WEST EIGHTEENTH AVENUE
COLUMBUS, OHIO 43210-1174

Catalog Description:

Single variable calculus treated in depth.

Prerequisites:

1151 or 151.xx, and permission of department.

Exclusions:

Not open to students with credit for any higher numbered math class.

Text:

Calculus with Analytic Geometry, 2nd edition, by Simmons, published by McGraw-Hill, ISBN: 9780070576424

Topics:

- 2.1 The Problem of Tangents
- 2.2 How to Calculate the Slope of the Tangent
- 2.3 The definition of the Derivative
- 2.4 Velocity and Rate of Change
- 2.5 The Concept of a Limit; Two Trigonometric Limits
- A2 Theorems about Limits;
- 3.1 Derivatives of Polynomials
- 3.2 The Product and Quotient Rules
- 3.3 Composite Functions and the Chain Rule
- 3.4 Some trig Derivatives;
- 3.5 Implicit Functions and Fractional Exponents
- 3.6 Derivatives of Higher Order
- 12.2 Indeterminate Form 0/0, L'Hopital's Rule
- 4.1 Increasing and Decreasing Functions, Maxima and Minima
- 4.2 Concavity and Points of Inflection
- 4.3 Applied Maxima and Minima Problems
- 4.4 Reflection & Refraction
- 4.5 Related Rates
- 2.6 Continuous Functions
- A4 The Mean Value Theorem
- Midterm I*
- 5.2 Differentials and Tangent Line Approx'n
- 5.3 Indefinite Integrals, Integration by Substitution;
- 5.4 Differential Equations, Separation of Variables
- 6.1 Introduction

Au

- 6.2 The Problem of Areas.
 6.3 The Sigma Notation and Certain Special Sums
 6.4 Area under a Curve, Definite Integrals, Riemann
 6.5 The Computation of Areas as Limits;
 6.6 The Fundamental Theorem of Calculus
 6.7 Algebraic and Geometric Areas
 7.2 Area between Two Curves;
 7.3 Volumes: The Disk Method
 7.4 Volumes: The Method of Cylindrical Shells
 7.5; 7.6 Arc Length; Area of a Surface of Revolution
 7.7 Work and Energy
 8.2 Review of Exponents and Logarithms;
 8.3 The number e and the function $y=e^x$
 8.4 The Natural Logarithm Function, Euler
 8.5 Applications, Population Growth and Radioactive Decay
 9.1; 9.2 Review of Trig.; Der'ive and Integrals of Sin and Cos
 9.3; 9.4 Der'ive of the Other Four Fns
 9.5 The Inverse Trig Functions
 9.6; 9.7 Simple Harmonic Motion; ("Optional") Hyperbolic Functions
MIDTERM 2
 10.1; 10.2 Basic Formulas; Method of Substitution
 10.3; 10.4 Certain Trig Integrals; Trig Substitutions;
 10.5; 10.6 Completing the Square
 10.7 Integration by Parts
 10.8 Strategy for Dealing with Integrals
 12.2; 12.3 Indeterminate Form $0/0$, L'Hopital's Rule; Other Indeterminate Forms
 12.3; 12.4 Improper Integrals
 13.1 What is an Infinite Series?;
 13.2 Convergent Sequences
 13.3 Convergent and Divergent Series
 13.4 General Properties of Convergent Series
 13.5 Series of Non-negative Terms, Compar. Tests
 13.6 Integral Test, Euler's Constant
 13.7 Ratio and Root Test
 13.8 Alternating Series Test, Absolute Convergence
MIDTERM 3
 14.2 The Interval of Convergence
 14.3 Differentiation and Integration of Power Series
 14.4 Taylor' Series and Taylor's Formula
 14.5 Computations Using Taylor's Formula
 14.6 Applications to Differential Equations
 14.8 Operations on Power Series
FINAL

Prerequisite:

Permission of Department.

Catalog Description:

An advanced enrichment course for interested and capable students.

Purpose of Course:

To offer an experience in problem solving in mathematics for interested and talented students beyond what they would encounter in a standard program. It is preparation for the National Putnam Mathematics Exam. This course is repeatable to a maximum of 6 credit hours, and is graded S/U. This course may not be counted in a major or minor program in Mathematics.

Topics:

Interesting special problems as chosen by the instructor.

DEPARTMENT OF MATHEMATICS
THE OHIO STATE UNIVERSITY
231 WEST EIGHTEENTH AVENUE
COLUMBUS, OHIO 43210-1174

Catalog Description:

Seminar on mathematical topics for beginning math and actuarial science majors.

Prerequisite:

Enrollment in math or actuarial science major, or permission of department.

Topics List:

1. Overview of the scope of mathematics, its subfields, and its applications.
2. Discussion of the OSU math major and differences among the tracks.
3. Outline of programs and activities that can benefit math majors.
4. Presentation of various different sorts of career opportunities for math majors.

DEPARTMENT OF MATHEMATICS
THE OHIO STATE UNIVERSITY
231 WEST EIGHTEENTH AVENUE
COLUMBUS, OHIO 43210-1174

Catalog Description:

Multivariable differential and integral calculus.

Prerequisites:

C- or better in 1152, 1172, 1534, 1544, 1181H, or 4181H; or credit for 153.xx, 154, 162.xx, or 162.01H.

Exclusions:

Not open to students with credit for any higher numbered math class, or for any quarter math class numbered 254 or higher.

Text:

Calculus for Scientists and Engineers: Early Transcendentals, 1st OSU custom edition, by Briggs, Cochran, Gillett, Pearson, published by Pearson, ISBN: Loose-leaf/Full Book: 978125678771X, Hardcover/Full Book: 9781256776467

Topics:

CHAPTER 12. Vectors and Vector-Valued Functions

- Section 1. Vectors in the Plane
- Section 2. Vectors in Three Dimensions
- Section 3. Dot Products
- Section 4. Cross Products
- Section 5. Lines and Curves in Space
- Section 6. Calculus of Vector-Valued Functions
- Section 7. Motion in Space
- Section 8. Length of Curves
- Section 9. Curvature and Normal Vectors

CHAPTER 13. Functions of Several Variables

Section 1. Planes and Surfaces, and brief conic section review
via pages 761 to 766 of Section 11.4

Section 2. Graphs and Level Curves

Section 3. Limits and Continuity

Section 4. Partial Derivatives

Section 5. The Chain Rule

Section 6. Directional Derivatives and the Gradient

Section 7. Tangent Planes and Linear Approximation

Section 8. Maximum/Minimum Problems

Section 9. Lagrange Multipliers

CHAPTER 14. Multiple Integration

Section 1. Double Integrals over Rectangular Regions

Section 2. Double Integrals over General Regions

Section 3. Double Integrals in Polar Coordinates

Section 4. Triple Integrals

Section 5. Triple Integrals in Cylindrical and Spherical Coordinates

Section 6. Integrals for Mass Calculations

Section 7. Change of Variables in Multiple Integrals

CHAPTER 15. Vector Calculus

Section 1. Vector Fields

Section 2. Line Integrals

Section 3. Conservative Vector Fields

Section 4. Green's Theorem

Section 5. Divergence and Curl

Section 6. Surface Integrals

Section 7. Stokes' Theorem

Section 8. Divergence Theorem

Mathematics 2162.01 (Sp)
Mathematics 2162.02 (Au, Sp)

5 credits each

Accelerated Calculus II
Accelerated Calculus II
for Honors Engineers

Catalog Description:

Multivariable calculus; introduction to Taylor series.

Prerequisites:

C- or better in 1161.xx or 1181H.

Exclusions:

For 2162.01: Not open to students with credit for any higher numbered math class numbered 2162 or higher.

For 2162.02: Intended for students in Freshman Engineering Honors and not open to students with credit for any higher numbered math class numbered 2162 or higher.

Text:

Calculus for Scientists and Engineers: Early Transcendentals, 1st OSU custom edition, by Briggs, Cochran, Gillett, Person, published by Pearson, ISBN: Loose-leaf/Full Book: 978125678771X, Hardcover/Full Book: 9781256776467

Topics:

- 9.1; 9.2 An Overview; Sequences
- 9.2; 9.3 Sequences; Infinite Series
- 9.4 Divergence and Integral Tests
- 9.5 Ratio, root, and Comparison Tests
- 9.5; 9.6 Ratio, root, and Comparison Tests; Alternating Series;
- 10.1; 10.2 Approximating Functions with Polynomials; Properties of power Series
- 10.3; 10.4 Taylor Series; Working with Taylor Series

- 11.1; 11.2 Parametric Equations; Polar Coordinates
- 11.2; 11.3 Polar Coordinates; Calculus in Polar Coordinates

Midterm 1

DEPARTMENT OF MATHEMATICS
THE OHIO STATE UNIVERSITY
331 WEST EIGHTEENTH AVENUE
COLUMBUS, OHIO 43210-1174

Mathematics 2162.01 (Sp)
Mathematics 2162.02 (Au, Sp)

5 credits each

Accelerated Calculus II
Accelerated Calculus II
for Honors Engineers

12.1; 12.2 Vectors in the Plane; Vectors in Three Dimensions
12.3;12.4 Dot Products; Cross Products
12.5 Lines and Curves in Space
12.6 Calculus of Vector-Valued Functions
12.7; 12.8 Motion in Space; Length of Curves
12.9 Curvature and Normal Vectors
13.1; 13.2 Planes and Surfaces; Graphs and Level Curves
13.3 Limits and Continuity
13.4;13.5 Partial Derivatives; Chain Rule
13.6 Directional derivative and the Gradient

MIDTERM 2

13.7 Tangent Plane and Linear Approximation
13.8 Maximum/Minimum Problems
13.9 Lagrange Multipliers
14.1; 14.2 Double Integral over Rectangular Regions; Double Integrals over General Regions
14.2; 14.3 Double Integrals over General Regions; Double integrals in Polar Coordinates
14.4; 14.5 Triple Integrals; Triple Integrals in Cylindricals and Sphericals
14.5; 14.6 Triple Integrals in Cylindricals and Sphericals; Integrals for Mass Calculations
15.1 Vector Fields
15.2 Line Integrals
15.3 Conservative Vector Fields

MIDTERM 3

15.4 Green's Theorem
15.5 Divergence and Curl
15.6 Surface Integrals
15.7 Stokes' Theorem
15.8 Divergence Theorem

DEPARTMENT OF MATHEMATICS
THE OHIO STATE UNIVERSITY
231 WEST EIGHTEENTH AVENUE
COLUMBUS, OHIO 43210-1174

Catalog Description:

Concepts of Calculus for Middle School Math teachers.

Prerequisite:

A grade of C- or above in 1165, or credit for 1164 or 110; and enrollment in Middle Childhood Education major or pre-major with Math as area of concentration.

Exclusions:

Not open to students with credit for 111.

Purpose of Course:

The purpose of the course is to prepare teachers of middle school students. In particular, it intends to deepen and extend the prospective teachers' content knowledge of the mathematics and mathematical reasoning that they will teach as well as their ability to reason with and communicate that knowledge.

Follow-up Courses:

Math 2168

Text:

Under Consideration

Supplementary Text: Course Notes

Topics List:

1. Rates described pictorially, in writing, and with symbols.
2. Informal and formal measurement of (instantaneous) rates and their connection to middle school mathematics.
3. Informal and formal measurement of (accumulated) areas and their connection to middle school mathematics.
4. The Fundamental Theorem of Calculus.
5. Applications of differential calculus.
6. Applications of integral calculus.

Prerequisite:

C- or better in 2167; or credit for 111. Limited to Middle Childhood majors and pre-majors with Math as an Area of Concentration.

Catalog Description:

Historical and mathematical discussion of topics in the middle school math curriculum.

Purpose of Course:

The purpose of the course is to prepare prospective middle school math teachers. In particular, it intends to deepen and extend prospective teachers' connections among topics in mathematics through the study of the history of mathematics, as well as continuing to develop their ability to reason with and communicate that knowledge.

Follow-up Courses:

None

Text:

Math through the Ages: A Gentle History for Teachers & Others, Expanded Edition, by Berlinghoff & Bouvea, published by Mathematical Association, ISBN: 9780883857366

Course Packet

Topics List:

1. History of Mathematics, from ancient to modern times.
2. Development of number systems, operations, geometry, trigonometry, algebra, calculus, statistics, and probability.
3. Applications: modeling real-world topics.
4. Problem solving (a theme throughout the course).

**DEPARTMENT OF MATHEMATICS
THE OHIO STATE UNIVERSITY
231 WEST EIGHTEENTH AVENUE
COLUMBUS, OHIO 43210-1174**

Catalog Description:

Multiple integrals, line integrals, vector fields, second order ordinary differential equations.

Prerequisite:

Math 1172, 1544, or 154.

Exclusions:

Not open to students with credit for 1152, 2153, or for any higher numbered math class, or for any quarter-system math class numbered 254 or higher.

Text:

Calculus for Scientists and Engineers: Early Transcendentals, 1st OSU custom edition, by Briggs, Cochran, Gillett, published by Pearson,
ISBN: Looseleaf/Full Bk: 978125678771X, Hardcover/Full Bk: 9781256776467

Topics List:

- 13.6 (Review of) Directional Derivatives and the Gradient Vector
- 13.8 Maximum and Minimum Values
- 13.9 Lagrange Multipliers
- 14.1 Double Integrals over Rectangular Regions
- 14.2 Double Integrals over General Regions
- 14.3 Double Integrals in Polar Coordinates

Midterm 1

- 14.4 Triple Integrals
- 14.5 Triple Integrals in Cylindrical & Spherical Coordinates
- 14.7 Change of Variables in Multiple Integrals
- 15.1 Vector Fields
- 15.2 Line Integrals
- 15.3 Conservative Vector Fields

Midterm 2

DEPARTMENT OF MATHEMATICS
THE OHIO STATE UNIVERSITY
331 WEST EIGHTEENTH AVENUE
COLUMBUS, OHIO 43210-1174
DEPARTMENT OF MATHEMATICS
THE OHIO STATE UNIVERSITY
231 WEST EIGHTEENTH AVENUE
COLUMBUS, OHIO 43210-1174

- 16.1 Basic Ideas of Second Order ODE's
- Appendix C Complex Arithmetic
- 16.2 Linear Homogeneous Equations
- 16.3 Linear Homogeneous Equations
- 16.4 Applications; Complex Forcing Functions

Final

DEPARTMENT OF MATHEMATICS
THE OHIO STATE UNIVERSITY
231 WEST EIGHTEENTH AVENUE
COLUMBUS, OHIO 43210-1174

DEPARTMENT OF MATHEMATICS
THE OHIO STATE UNIVERSITY
231 WEST EIGHTEENTH AVENUE
COLUMBUS, OHIO 43210-1174

Catalog Description:

Matrix theory, eigenvectors and eigenvalues, ordinary and partial differential equations.

Prerequisite:

2173 and either major in ENG, Physics, or Chemistry or permission of math department.

Exclusions:

Not open to students with credit for both (i) 2415 (415) or 2255 (255) and (ii) 2568 (568 or 571).

Text:

Part II: Elementary Ordinary & Partial Differential Equations, OSU custom edition, by Boyce, published by Wiley, ISBN: 9781119934462

Introduction to Linear Algebra, 5th edition, by Johnson, Riess and Arnold, published by Pearson, ISBN: 9780321628217

Topics List:

Part One = Matrix Algebra

Textbook sections from Arnold, Riess, and Johnson's *Introduction to Linear Algebra*, 5th edition

Chapter 1: Matrices and Linear Systems of Equations

Chapter 4: The Eigenvalue Problem

- 1.1 Introduction and Gaussian Elimination
- 1.2 Solution Sets for Linear systems
- 1.3 Matrices and Echelon form
- 1.4 Consistent Systems of Linear Equations
- 1.6 Matrix Operations
- 1.7 Algebraic Properties of Matrix operations
- 1.8 Linear Independence and Nonsingular Matrices

Midterm 1

- 4.1 The Eigenvalue Problem for 2×2 Matrices
- 4.2 Determinants and the eigenvalue Problem
- 4.4 Eigenvalues and characteristic Polynomial
- 4.5 Eigenvectors and Eigenspaces
- 4.6 Complex Eigenvalues and Eigenvectors
- 4.7 Similarity Xformations and Diagonalization

Part Two = Systems of Linear Differential Equations

Textbook Sections from Boyce & DiPrima's Part II: Elementary Ordinary & Partial Differential Equations

- Ch. 7: Systems of First Order Linear Equations
- Ch. 10: PDE's and Fourier Series

- 7.4 Basic Theory of Systems of 1st Order Linear Equations
- 7.5 Homogeneous Linear Systems with Constant Coefficients
- 7.6 Complex Eigenvalues
- 7.8 Repeated Eigenvalues

Midterm 2

Part Three = Partial Differential Equations and Fourier Series

- 10.1 Two point Boundary Value Problem
- 10.2 Fourier Series
- 10.3 The Fourier Convergence Theorem
- 10.4 Even and Odd Functions
- 10.5 Separation of Variables; Heat Conduction Equation
- 10.6 Other Heat Conduction Problems
- 10.7 The Wave Equation; Vibrations of an Elastic String
- 10.8 Laplace's Equation (optional)

DEPARTMENT OF MATHEMATICS
THE OHIO STATE UNIVERSITY
231 WEST EIGHTEENTH AVENUE
COLUMBUS, OHIO 43210-1174

Catalog Description:

Multiple integrals, line integrals; matrix algebra; linear (ordinary and partial) differential equations.

Prerequisite:

Major, pre-major, or minor in BiomedE, CEEGS, FABEng, MatScEn, CBE, or WeldEn; and: 1172, 2153, 1544 (154), 254.xx, 263.xx, 263.01H, or 264H

Exclusions:

Not open to students with credit for 2174 or 5520H; or with credit for both (i) 2415 (415), 2255 (255) or 4512 (512) and (ii) 2568 (568 or 571).

Text:

Math 2177, Custom Edition for OSU, Pearson, ISBN-13 978-1-256-82676-7 or ISBN-10 1-256-82676-6 –OR– the textbooks listed below.

Topics List:

PART ONE: Multivariable Integral Calculus

Textbook Sections from *Calculus for Scientists and Engineers: Early Transcendentals*, by Briggs, Cochran, Gillett and Shulz, Chapters 13-15

| 2177 Custom | Original Text | Topic |
|----------------|------------------|---|
| 1.8 | 13.8 | Maximum/Minimum Problems |
| 1.9 | 13.9 | Lagrange Multipliers |
| 2.1 | 14.1 | Double Integrals over Rectangular Regions |
| 2.2 | 14.2 | Double Integrals over General Regions |
| 2.3 | 14.3 | Double Integrals in Polar Coordinates |
| 2.4 | 14.4 | Triple Integrals |
| 2.5 | 14.5 | Triple Integrals in Cylindrical and Spherical Coordinates |
| 2.7 | 14.7 | Change of Variables in Multiple Integrals |
| 3.1 | 15.1 | Vector Fields |
| 3.2 | 15.2 | Line Integrals |
| 3.3 | 15.3 | Conservative Vector Fields |

Midterm 1

PART TWO: Matrices and Linear Systems of Equations

Textbook Sections from *Introduction to Linear Algebra*, by Johnson, Riess, and Arnold, 5th edition, Chapter 1: Matrices and Systems of Linear Equations

| 2177 Custom | Original Text | Topic |
|----------------|------------------|---|
| 4.1 | 1.1 | Introduction to Matrices and Systems of Linear Equations |
| 4.2 | 1.2 | Echelon Form and Gauss-Jordan Elimination |
| 4.3 | 1.3 | Consistent Systems of Linear Equations |
| 4.4 | 4.4 | Applications (optional) |
| 4.5 | 1.5 | Matrix Operations |
| 4.6 | 1.6 | Algebraic Properties of Matrix operations |
| 4.7 | 1.7 | Linear Independence and Nonsingular Matrices |
| 4.8 | 1.8 | Data Fitting, Numerical Integration and Numerical Differentiation |

Midterm 2

PART THREE: 2nd Order Constant Coefficient O.D.E.'s

Textbook Sections from *Calculus for Scientists and Engineers: Early Transcendentals*, by Briggs, Cochran, Gillett and Shulz, Chapter 16 and Appendix C

| 2177 Custom | Original Text | Topic |
|----------------|------------------|---------------------------------|
| 5.1 | 16.1 | Basic Ideas |
| Appx C | Appx C | Complex Numbers |
| 5.2 | 16.2 | Linear Homogeneous Equations |
| 5.3 | 16.3 | Linear Nonhomogeneous Equations |
| 5.4 | 16.4 | Applications |

Midterm 3

PART FOUR: Fourier Series & Partial Differential Equations

Textbook Sections from *Fundamentals of Differential Equations and Boundary Value Problems*, by Nagle, Saff and Snider, 8th Edition, Chapter 10

| 2177 Custom | Original Text | Topic |
|----------------|------------------|-------------------------------------|
| 6.1 | 10.1 | Introduction: A Model for Heat Flow |
| 6.2 | 10.2 | Method of Separation of Variables |
| 6.3 | 10.3 | Fourier Series |
| 6.4 | 10.4 | Fourier Cosine and Sine Series |
| 6.5 | 10.5 | The Heat Equation |
| 6.6 | 10.6 | The Wave Equation |

Catalog Description:

Multivariable calculus treated in depth.

Prerequisite:

C or better in 1181H or 4181H.

Exclusions:

Not open to students with credit for both 162.01H and 263.01H

Text:

Calculus with Analytic Geometry, 2nd Edition, by George F. Simmons, published by McGraw-Hill, ISBN: 0070576424

Topics List:

- 15.1; 15.2 Conic sections: Ellipse, Parabola, Hyperbola
- 15.3; 15.4 Conic sections: Ellipse, Parabola, Hyperbola
- 16.1 Polar coordinate system
- 16.2 Graphs of polar equations
- 16.3 Polar Equations of conics and spirals
- 16.3; 16.4 Polar Equations of conics and spirals; Arc length and tangent lines
- 16.5 Areas in polar coordinates
- 17.1 Parametric Equations of Curves
- 17.2 Cycloids and other similar Figures
- 17.3 Vector Algebra, the Unit Vectors i and j ;
- 17.4 Derivatives of Vector Functions, Velocity and Acceleration
- 17.5 Curvature and the Unit Normal Vector
- 17.6 Tangential and Normal Components of Acceleration
- 17.7 Kepler's Laws and Newton's Law of Universal Gravitation

Midterm 1

- 18.1 Coordinates and Vectors in 3-D Space
- 18.2 The Cross Product of Two Vectors
- 18.3 The Dot Product of Two Vectors
- 18.4 Lines and Planes
- 18.5 Cylinders and Surfaces of Revolution
- 18.6 Quadratic Surfaces;
- 18.7 Cylindrical and Spherical Coordinates
- 19.1 Function of Several Variables
- 19.2 Partial Derivatives
- 19.3 The Plane Tangent to a Surface
- 19.4 Increments and Differentials, the Fundamental Lemma
- 19.5 Directional Derivatives and the Gradient
- 19.6 The Chain Rule for Partial Derivatives
- 19.7; 19.8 Maximum and Minimum Problems
- 19.10 Implicit Functions

Midterm 2

- 20.1 Volumes as Iterated Integrals
- 20.2 Double Integrals and Iterated Integrals
- 20.3 Physical Applications of Double Integrals
- 20.4 Double Integrals in Polar Coordinates
- 20.5 Triple Integrals
- 20.6 Cylindrical Coordinates
- 20.7 Spherical Coordinates, Gravitational Attraction
- 20.8 Area of Curved Surfaces

Midterm 3

- 21.1 Line Integrals in the Plane
- 21.2 Independence of Path, Conservative Fields
- 21.3 Green's Theorem
- 21.4 Surface Integrals and Gauss' Theorem
- 21.5 Stokes' Theorem

DEPARTMENT OF MATHEMATICS
THE OHIO STATE UNIVERSITY
231 WEST EIGHTEENTH AVENUE
COLUMBUS, OHIO 43210-1174
DEPARTMENT OF MATHEMATICS
THE OHIO STATE UNIVERSITY
231 WEST EIGHTEENTH AVENUE
COLUMBUS, OHIO 43210-1174

Catalog Description:

Ordinary differential equations, their series solutions, numerical methods, Laplace transforms, physical applications.

Prerequisite:

C- or better in 2153, 2162.xx, 2173, 2182H, or 4182H; or credit for 254.xx, 263.xx, 263.01H, or 264H.

Text:

Ordinary Differential Equations and their Applications, OSU custom edition, by Boyce, published by Wiley, ISBN 9781119934455

Topics List:

INTRODUCTION

- 1.3 Classification of Differential Equations
- 2.1 Linear Equations with Variable Coefficients

FIRST ORDER DIFFERENTIAL EQUATIONS

- 2.2 Separable Equations
- 2.4 Differences between Linear and Nonlinear Equations
- 2.5 Autonomous Equations and Population Dynamics
- 2.6 Exact Equations and Integrating Factors
- 2.7 Numerical Approximations: Euler's Method
- 2.8 The Existence and Uniqueness Theorem
- 2.9 First Order Difference Equations

SECOND ORDER LINEAR EQUATIONS

- 3.1 Homogeneous Equations with Constant Coefficients
- 3.3 Complex Roots of the Characteristic Equation
- 3.2 Solutions of Linear Homogeneous Equations; the Wronkian
- 3.4 Repeated Roots; Reduction of Order

Midterm 1

- 3.5 Nonhomogeneous Equations; Method of Undetermined Coefficients
- 3.6 Variation of Parameters
- 3.7 Mechanical and Electrical Vibrations
- 3.8 Forced Vibrations

THE LAPLACE TRANSFORM

- 6.1 Definition of the Laplace Transform
- 6.3 Step Functions
- 6.2 Solution of Initial Value Problems
- 6.4 Differential Equations with Discontinuous Forcing Functions
- 6.5 Impulse Functions
- 6.6 The Convolution Integral

Midterm 2

HIGHER ORDER LINEAR EQUATIONS

- 4.1 General Theory of nth Order Equations
- 4.2 Homogeneous Equations with Constant Coefficients
- 4.3 The Method of Undetermined Coefficients Material
- 4.4 The Method of Variation of Parameters

SERIES SOLUTIONS OF SECOND ORDER LINEAR EQUATIONS

- 5.1 Review of Power Series
- 5.2 Series Solutions near an Ordinary Point, Part I
- 5.3 Series Solutions near an Ordinary Point, Part II
- 5.4 Euler's Equation; Regular Singular Points

Midterm 3

- 5.5 Series Solutions near a Regular Singular Point, Part I
- 5.6 Series Solutions near a Regular Singular Point, Part II
- 5.7 Bessel's Equation

DEPARTMENT OF MATHEMATICS
THE OHIO STATE UNIVERSITY
231 WEST EIGHTEENTH AVENUE
COLUMBUS, OHIO 43210-1174

Mathematics 2366
Sp

2 credits

Introduction to Discrete Mathematics

Catalog Description:

Mathematical reasoning, logic, sets, functions, recursive definitions, elementary counting principles.

Prerequisites:

C- or better in 1131 or 1151; credit for 132 or 152.xx; or permission of department.

Exclusions:

Open only to majors in MIS (Management Information Systems). Not open to students with credit for 366.

Text:

Discrete Mathematics with Applications, 4th edition, by Epp, published by Cengage, ISBN: 9780495391326, Lecture Notes by G. Baker.

Topics List:

Topics for this discrete math course depend on future discussions with colleagues in Management Information Systems.

**DEPARTMENT OF MATHEMATICS
THE OHIO STATE UNIVERSITY
231 WEST EIGHTEENTH AVENUE
COLUMBUS, OHIO 43210-1174**

Catalog Description:

Ordinary and partial differential equations: Fourier series, boundary and initial value problems.

Prerequisite:

2153, 2162.xx, 2173, 2182H, 4182H, both (1172 or 1544 or 154) and 2568, 254.xx, 263.xx, 263.01H, or 264H.

Exclusions:

Not open to students with credit for Math 2255, 5520H, 2174, 255, 415.xx, or 521H.

Textbook:

Elementary Differential Equations and Boundary Value Problems, 10th Edition, by W. Boyce and R. DiPrima, ISBN 978-1-118-15738-1

-or- Lectures Notes, by Greg Baker, published by Zip Printing.

Topics List:

- 1.1 Some Basic Mathematical Models & Direction Fields
- 1.3 Classification of Differential Equations
- 1.2 Solutions to some Differential Equations
- 2.2 Separable Equations
- 2.1 Linear Equations with Variable Coefficients
- 2.3 Modeling with First Order Differential Equations
- 2.4 Difference between Linear and Nonlinear Equations
- 2.5 Autonomous Equations and Population Dynamics
- 3.1 Homogeneous Equations with Constant Coefficients;
- 3.3 Complex Roots of the Characteristic Equation
- 3.4 Repeated Roots

Midterm 1

DEPARTMENT OF MATHEMATICS
THE OHIO STATE UNIVERSITY
331 WEST EIGHTEENTH AVENUE
COLUMBUS, OHIO 43210-1174

DEPARTMENT OF MATHEMATICS
THE OHIO STATE UNIVERSITY
231 WEST EIGHTEENTH AVENUE
COLUMBUS, OHIO 43210-1174

- 3.2 Solutions of Linear Homogeneous Equations; the Wronskian
- 3.4 Reduction of Order
- 4.5 Non-homogeneous Equations; Method of Undetermined Coefficients
- 3.7 Mechanical and Electrical vibrations
- 3.9 Forced Vibrations
- 10.1 Two-point Boundary Value Problem

Midterm 2

- 10.2 Fourier Series
- 10.3 The Fourier Convergence Theorem
- 10.4 Even and Odd Functions
- 10.5 Separation of Variables; Heat Conduction in a Rod
- 10.7 Wave Equation: Vibrations of an Elastic String
- 7.1 Introduction
- 7.3 Systems of Linear Algebraic Equations; Linear Independence, Eigenvalues, Eigenvectors
- 7.5 Homogeneous Linear Systems with Constant Coefficients
- 7.6 Complex Eigenvalues
- 7.4 Basic Theory of Systems of 1st Order Linear Equations

DEPARTMENT OF MATHEMATICS
THE OHIO STATE UNIVERSITY
231 WEST EIGHTEENTH AVENUE
COLUMBUS, OHIO 43210-1174

DEPARTMENT OF MATHEMATICS
THE OHIO STATE UNIVERSITY
231 WEST EIGHTEENTH AVENUE
COLUMBUS, OHIO 43210-1174

Catalog Description:

Matrix algebra, vector spaces and linear maps, bases and dimension, eigenvalues and eigenvectors, applications.

Prerequisite:

C- or above in 1172, 1544, 2153, 2162.xx, 2182H, or 4182H; or C- or above in both 1152 and CSE 2321; or credit for 154, 254.xx, 263.xx, 263.01H, or 264H.

Exclusions:

Not open to students with credit for 4568 (568), 5520H (520H), or 572.

Text:

Introduction to Linear Algebra, 5th edition, by L.W. Johnson, R.D. Riess, and J.T. Arnold, published by Pearson, ISBN Softcover: 0321628217, Hardcover: 0201658593

Topics List:

Part I

- 1.1 Introduction to Matrices and Systems of linear equations
 - 1.2 Echelon Form and Gaussian-Jordan Elimination
 - 1.3 Consistent Systems of linear Equations
 - 1.5 Matrix Operations
 - 1.6 Algebraic Properties of Matrix operations
 - 1.7 Linear Independence and Nonsingular Matrices
 - 1.9 Matrix Inverses and Their Properties
- Midterm 1

DEPARTMENT OF MATHEMATICS
THE OHIO STATE UNIVERSITY
331 WEST EIGHTEENTH AVENUE
COLUMBUS, OHIO 43210-1174
DEPARTMENT OF MATHEMATICS
THE OHIO STATE UNIVERSITY
231 WEST EIGHTEENTH AVENUE
COLUMBUS, OHIO 43210-1174

Part II

- 2.1 Vectors in The Plane (Review only because it was done in 1152)
 - 2.2 Vectors in Space (Review only because it was done in 1152)
 - 2.3 The Dot Product and The Cross
 - 3.1 Introduction
 - 3.2 Vector Space Properties of \mathbb{R}^n
 - 3.3 Examples of Subspaces
 - 3.4 Bases for Subspaces
 - 3.5 Dimension
 - 5.2 Vector Spaces
 - 5.3 Subspaces
 - 5.4 Linear Independence, Bases, and Coordinates
 - 3.6 Orthogonal Bases for Subspaces
 - 3.7 Linear Transformation from \mathbb{R}^n to \mathbb{R}^m
- Midterm 2

Part III

- 4.1 The Eigenvalue Problem for 2×2 Matrices
 - 4.2 Determinants and the Eigenvalue Problem
 - 4.4 Eigenvalues and Characteristic Polynomial
 - 4.5 Eigenvectors and Eigenspaces
 - 4.6 Complex Eigenvalues and Eigenvectors
 - 4.7 Similarity Transformations and Diagonalization
- Final

DEPARTMENT OF MATHEMATICS
THE OHIO STATE UNIVERSITY
231 WEST EIGHTEENTH AVENUE
COLUMBUS, OHIO 43210-1174
DEPARTMENT OF MATHEMATICS
THE OHIO STATE UNIVERSITY
231 WEST EIGHTEENTH AVENUE
COLUMBUS, OHIO 43210-1174

Mathematics 3345
Au, Sp

3 credits

Foundations of Higher Mathematics

Catalog Description:

Introduction to logic, proof techniques, set theory, number theory, real numbers.

Prerequisite:

Major or minor in Math, CSE, or CIS.

Math: C- or better in 2153, 2162.xx, 2173, or 2182H; or credit for 254.xx, 263.xx or 263.01H.

CIS or CSE:

C- or better in both CSE 2321 and: C- or better in 1152, 1161.xx, 1172, 1181H, 1534, or 1544; or credit for 153.xx, 154, 162.xx, or 162.01H.

Exclusions:

Not open to students with credit for 345.

Text:

Lecture Notes, by N. Falkner.

Topics List:

1. Propositional calculus; quantifiers.
2. Simple examples of mathematical proofs.
3. Mathematical induction.
4. Sets and functions: surjections, injections, bijections.
5. Infinite sets: countable and uncountable.

**DEPARTMENT OF MATHEMATICS
THE OHIO STATE UNIVERSITY
231 WEST EIGHTEENTH AVENUE
COLUMBUS, OHIO 43210-1174**

Mathematics 3350
Sp

3 credits

Introduction to Mathematical Biology

Catalog Description:

Introduction to quantitative and qualitative analysis of several mathematical models for biological systems.

Purpose:

This course prepares students with basic knowledge in mathematical analysis of some differential equation models, as well as numerical tools for simulating those models.

Prerequisite:

C- or better in Math 2255, 2415, 5520H; or credit for 255, 415.xx, or 521H.

Text:

Lecture Notes

Topics List:

1. Population dynamics: Logistic growth.
2. Population dynamics: Lotka-Volterra predator-prey model.
3. Modeling specific diseases (e.g. HIV, cancer).
4. Competition model.
5. Dynamics of a neuron.
6. Enzyme kinetics.
7. Cell proliferation and death.

**DEPARTMENT OF MATHEMATICS
THE OHIO STATE UNIVERSITY
231 WEST EIGHTEENTH AVENUE
COLUMBUS, OHIO 43210-1174**

Mathematics 3532
Sp

3 credits

**Mathematical Foundations of
Actuarial Science**

Catalog Description:

Problem workshop for applications of calculus and probability to actuarial science and risk management.

Prerequisite:

C- or better in Math 4530, 5530H, or Stat 4201; or credit for 530, 531H, or Stat 420.

Topics List:

1. Random variables.
2. Discrete distributions.
3. Continuous distributions.
4. Central Limit Theorem and law of large numbers.
5. Risk models.

Mathematics 3588
Sp

3 credits

Practicum in Actuarial Science

Catalog Description:

Presentations by practicing actuaries on topics drawn from their fields of expertise; oral presentations by students on selected topics in actuarial science.

Prerequisite:

3rd year standing and completion of second writing course.

*Require 3618
as prereq?*

Exclusions:

Open only to actuarial science majors.

Text:

None.

Topics List:

1. Business communication.
2. Problems in life insurance.
3. Problems in property and casualty insurance.
4. Problems in pension consulting.
5. Problems in health care consulting.
6. Risk management.

Catalog Description:

Introduction to mathematics used in financial asset pricing, based on the binomial asset pricing model. This course prepares students for further study of stochastic calculus in continuous time.

Purpose:

This course is designed as an introduction to the concepts encountered in financial mathematics for students who don't have a background in continuous-time stochastic calculus.

Prerequisite:

{C- or better in 3345 or credit for 345}; and {C- or better in 4530, 5530H, or Stat 4201, or credit for 530, 531H, 345 or Stat 420}; or permission of department.

Text:

Stochastic Calculus for Finance I, The Binomial Asset Pricing Model, by Shreve, published by Springer, ISBN: 9780387249681

Topics List:

1. First principles; assumptions about stock behavior and description of basic financial instruments; put and call options.
2. Arbitrage, and no-arbitrage pricing.
3. One-period and multi-period models; replication and hedging.
4. Conditional expectations.
5. Martingales and Markov processes.
6. Change of measure.
7. Utility functions and the capital asset pricing model.
8. Stopping times and American derivatives.
9. Random walks and passage times.

Catalog Description:

Introduction to uses of computers to solve problems arising in the physical and biological sciences, and in engineering and finance.

Prerequisite:

{C- or better in 2255, 2415, or 5520H; and C- or better in 2568 or 5520H}; or:
{credit for 255, 415.xx, or 521H; and credit for 568, 571, or 520H}.

Purpose:

Math 3607 is a course which has three main goals: it introduces students to MATLAB (or improves their knowledge of MATLAB); it uses MATLAB to solve practical problems from various areas of mathematics, physics, engineering, business, and finance; and it presents the numerical analysis needed to use MATLAB effectively. The principle underlying this course is that the way to learn MATLAB and numerical analysis is by doing it, not by reading about it. This course is taught in a computer lab and MATLAB will be used to some extent every class.

Textbook:

Learning MATLAB, Problem Solving, and Numerical Analysis through Examples, by Ed Overman (downloadable e-book).

Topics List:

1. MATLAB as a scalar calculator, round-off errors, debugging.
2. Arrays in MATLAB, probability theory, Markov processes.
3. Graphics in MATLAB, applications of probability theory, histograms.
4. Programming in MATLAB, more probability theory, mathematical biology.
5. Function m-files in MATLAB, more Markov processes, chaos.
6. More about functions, randomness.
7. Solving linear systems of equations.
8. Interpolation and approximation.
9. The solution of nonlinear equations and unconstrained optimization.
10. Numerical differentiation and integration
11. Time-evolution ordinary differential equations, boundary-value ordinary differential equations, stochastic differential equations, examples from many disciplines.
12. Eigenvalues, Fourier series.

DEPARTMENT OF MATHEMATICS
THE OHIO STATE UNIVERSITY
231 WEST EIGHTEENTH AVENUE
COLUMBUS, OHIO 43210-1174

Math 3607

Course Coordinator: E. Overman

2013-2014

Catalog Description:

Financial transactions involving interest: measurement of interest, force of interest, annuities-certain, introduction to financial derivatives.

Prerequisite:

C- or better in 1152, 2162.xx, 1172, 2182H, 4181H; or credit for 153, 162, 162H, or 191H.

Exclusions: Open only to actuarial science majors and pre-majors, and to math majors.

Text:

Mathematics of Investment & Credit, 5th edition, by Broverman, published by Actex. ISBN: 9781566987677

Derivatives Markets, 2nd edition, by McDonald, published by Pearson, ISBN: 9780321280305

Topics List:

1. Compound and simple rates of interest and discount, force of interest.
2. Annuity certain and annuity due.
3. Mortgage amortizations.
4. Evaluation of bonds.
5. Durations.
6. Asset and liability matching.
7. Introduction to options, futures, and other derivatives.

Catalog Description:

4181H-4182H is an enriched honors sequence introducing students to mathematical underpinnings of calculus.

Prerequisite:

Permission of department.

Text:

Calculus, 4th edition, by Spivak, published by Publish or Perish, ISBN: 9780914098918.

Topics List:

1. Functions and limits.
2. Continuity.
3. Derivatives and integrals.
4. Infinite sequences and series.

Catalog Description:

Continuation of Math 4181H.

Prerequisite:

B- or better in 4181H, or permission of department.

Text:

Advanced Calculus, by Folland, published by Pearson, ISBN: 9780130652652

Topics List:

1. Uniform convergence and power series. Taylor series and remainder terms.
2. Multiple integrals.
3. Line integrals and vector fields; surface integrals.
4. Green's Theorem.
5. Curl, divergence, Stokes' Theorem, Divergence Theorem.
6. Functions defined by series or integrals.

Mathematics 4504
Sp, Su

3 credits

History of Mathematics

Catalog Description:

Development of mathematics from primitive origins to present forms. Topics include: development of arithmetic, algebra, geometry, trigonometry, and calculus.

Prerequisite:

C- or better in 2568, 4507, or 5520H; or credit for 568, 571, 507, 580, or 520H; or permission of department.

Exclusions:

Open only to math majors, or students with graduate standing in Ed T&L. Not open to students with credit for 504.

Text:

Journey through Genius, by William Dunham, published by Wiley, ISBN: 0471500305

Topics List:

1. Development of arithmetic; Babylonian tablets and Egyptian papyri.
2. Development of geometry: Pythagoras, Thales, Euclid, Archimedes, Ptolemy, and non-Euclidean geometry.
3. Development of algebra and calculus.

Mathematics 4507
Au, Sp

3 credits

Geometry

Catalog Description:

Topics in Euclidean, spherical, and hyperbolic geometries.

Prerequisite:

C- or better in 3345 and in C- or better in 2568 or 5520H; or credit for 345, and credit for 568, 571, or 520H; or graduate standing.

Text:

None.

Topics List:

1. Euclidean geometry.
2. Spherical geometry.
3. Hyperbolic geometry.

**DEPARTMENT OF MATHEMATICS
THE OHIO STATE UNIVERSITY
231 WEST EIGHTEENTH AVENUE
COLUMBUS, OHIO 43210-1174**

Catalog Description:

Second-order PDEs; boundary value problems; Fourier series; wave, heat and Laplace equations; applications.

Prerequisite:

C- or better in 2173, 2153, 2162.xx, 2182H, or 4182H; or credit for 254.xx, 263.xx, 263.01H, or 264H. Intended for undergraduate and master degree students in Engineering and Science.

2177 ok for prereq

Exclusions:

Not open to students with credit for 4557, 512, or 557.

Not open to students with a math major, math minor or actuarial science major.

Purpose of Course:

This course develops problem solving skills with little emphasis on theory. Students should be able to solve the PDE's and ODE's and interpret the solution.

Text:

Partial Differential Equations & Boundary Value Problems, 9th OSU custom edition, by Boyce, published by Wiley, ISBN: 9781119935148

Topics List:

- Part I: ODE's via The Laplace Transform (Chapter 6);
Euler's and Bessel's Equation (1/2 of Chapter 5)*
- 6.1 Definition of the Laplace Transform
 - 6.2 Solution of Initial Value Problems
 - 6.3 Step Functions
 - 6.4 Diff'l Equations with Discontinuous Forcing Functions
 - 6.5 Impulse Functions
 - 6.6 Convolution Integral
 - 5.4 Euler's Equation; Regular Singular Points
 - 5.5 Series Solution near a Singular Point: Part I
 - 5.6 Series Solution near a Singular Point: Part II
 - 5.7 Bessel's Equation

DEPARTMENT OF MATHEMATICS
THE OHIO STATE UNIVERSITY
381 WEST EIGHTEENTH AVENUE
COLUMBUS, OHIO 43210-1174

DEPARTMENT OF MATHEMATICS
THE OHIO STATE UNIVERSITY
231 WEST EIGHTEENTH AVENUE
COLUMBUS, OHIO 43210-1174

Midterm I

Part II: Partial Differential Eq'n and Fourier Series (Chapter 10)

- 10.1 The Two-Point Boundary Value Problem
- 10.2 Fourier Series
- 10.3 Fourier Convergence Theorem
- 10.4 Even and Odd Functions
- 10.8A Heat Conduction Eq'n: Motivation via Derivation
- 10.5 Separation of Variables; Heat Conduction in a Rod
- 10.6 Other Heat Conduction Prob's: Nonhomogeneous, Neuman, Mixed Boundary Cond'ns
- 10.8B Wave Equation: Motivation via Derivation;
- 10.7 Vibrations of an Elastic String
- 10.8 Laplace's Equation: Separation in Cartesian Coordinates Dirichelet vs. Neuman Boundary Condxns
- 10.8 Separation and Solution in Polar and Cylindrical Coordinates

Midterm II

Part III: Boundary Value Problems (Chapter 11)

- 11.1 Two-point Boundary Value Problems
- 11.2 Sturm-Liouville Boundary Value Problems I
- 11.2 Sturm-Liouville Boundary Value Problems II
- 11.3 Nonhomogeneous Boundary Value Problems
- 11.4 Singular Sturm-Liouville Problems
- 11.5 Bessel Series Expansion: Vibrating Drum
- 11.6 (If time permits: Series of Orthogonal Functions: Mean Convergence)

DEPARTMENT OF MATHEMATICS
THE OHIO STATE UNIVERSITY
231 WEST EIGHTEENTH AVENUE
COLUMBUS, OHIO 43210-1174

DEPARTMENT OF MATHEMATICS
THE OHIO STATE UNIVERSITY
231 WEST EIGHTEENTH AVENUE
COLUMBUS, OHIO 43210-1174

Mathematics 4530
Au, Sp, Su

3 credits

Probability

Catalog Description:

Combinatorial probability, random variables, independence, expectation, variance.

Purpose:

This is an introductory probability course designed to give students a firm grasp of random variables, where they occur, and how they are used, and to develop the computational tools necessary to work with them.

Prerequisite:

C- or better in 2153, 2162.xx, 2173, 2177, 2182H, 4182H; or credit for 254.xx, 263.xx, 263.01H, or 264H.

Exclusions:

Not open to students with credit for any of 530, 5530H (531H), or Stat 4201 or 420.

Follow-up Courses:

Math 3532 (actuarial science majors), Math 3589 (financial math), Stat 4202.

Text:

Probability, by Pitman, published by Springer, ISBN: 9780387979748

DEPARTMENT OF MATHEMATICS
THE OHIO STATE UNIVERSITY
831 WEST EIGHTEENTH AVENUE
DEPARTMENT OF MATHEMATICS
THE OHIO STATE UNIVERSITY
231 WEST EIGHTEENTH AVENUE
COLUMBUS, OHIO 43210-1174

Topics List:

I. Discrete probability.

1. First principles: outcome spaces, basic counting techniques, and partitions.
2. Venn diagrams and the inclusion-exclusion principle.
3. Conditional probability and independence; decision trees and Bayes' Theorem.
4. Discrete random variables; mass and generating functions; joint distributions.
5. Binomial, hypergeometric, geometric, negative binomial, and Poisson variables; applications and relationships.
6. Statistics on discrete variables.

II. Continuous probability

7. First principles: density functions, calculation of probabilities and statistics.
8. Moments and moment-generating functions.
9. Common distributions and their applications; exponential, gamma, uniform, normal.
10. The central limit theorem and normal approximation to the binomial distribution.
11. Relationships between the exponential, gamma, and Poisson distributions.
12. Hazard rates and survival functions.
13. Cumulative distribution functions, percentiles, and change of variables.
14. Joint distribution of continuous variables; independence and marginal distributions; density of a function of two variables

DEPARTMENT OF MATHEMATICS
THE OHIO STATE UNIVERSITY
231 WEST EIGHTEENTH AVENUE
COLUMBUS, OHIO 43210-1174

Catalog Description:

Topics in calculus and analysis.

Prerequisites:

Either C- or better in 2153, 2162.xx, 2173, 2182H, or 4182H; or credit for 254, 263.xx, 263.01H, 264H, or equivalent;
-and- C- or better in Math 2568, 5520H, or equivalent.

Exclusions: Entry to this course is restricted to graduate students in Statistics or Biostatistics who have permission from the Departments of Statistics or Biostatistics.

Text:

Introduction to Real Analysis, by William F. Trench, Edition 1.03, published by Library of Congress Cataloging-in-Publication Data, ISBN: 0-13-045786-8

Topics List:

1. Limits and continuity of functions.
2. Derivative, mean value theorem, optimization.
3. Sequences and series, uniform convergence, power series, Taylor's theorem.
4. Riemann integral, substitution, bounded variation, limit properties, Riemann-Stieltjes integral.
5. Multivariable functions, directional derivatives, chain rule, Taylor's theorem.
6. Inverse and implicit function theorems, Lagrange multipliers, multiple integrals, Jacobians, differentiation under the integral sign.

DEPARTMENT OF MATHEMATICS
THE OHIO STATE UNIVERSITY
231 WEST EIGHTEENTH AVENUE
COLUMBUS, OHIO 43210-1174

Mathematics 4547
Au, Sp

3 credits

Introductory Analysis I

Catalog Description:

4547-4548 involves advanced calculus covering: sequences, limits, continuity, differentiation, Riemann integral, sequences and series of functions, Taylor series, and improper integrals.

Prerequisite:

C- or better in 3345; or credit for 345.

Text:

Introduction to Real Analysis, 4rd edition, by Bartle & Sherbert, published by Wiley, ISBN: 9780471433316

Topics List:

1. Sequences and their limits.
2. Bolzano-Weierstrass Theorem and Cauchy's criterion.
3. Convergence and absolute convergence of series. Tests for convergence.
4. Power series.
5. Continuous functions.

**DEPARTMENT OF MATHEMATICS
THE OHIO STATE UNIVERSITY
231 WEST EIGHTEENTH AVENUE
COLUMBUS, OHIO 43210-1174**

Mathematics 4548
Au, Sp

3 credits

Introductory Analysis II

Catalog Description:

Continuation of Math 4547.

Prerequisite:

C- or better in 4547, or credit for 548.

Text:

Introduction to Real Analysis, 4th edition, by Bartle & Sherbert, published by Wiley,
ISBN: 9780471433316

Topics List:

1. Uniform continuity.
2. Derivatives.
3. Mean Value Theorem, L'Hôpital's rule.
4. Taylor series.
5. Riemann integral.
6. Exponential and logarithmic functions.
7. Sequences and series of functions.

**DEPARTMENT OF MATHEMATICS
THE OHIO STATE UNIVERSITY
231 WEST EIGHTEENTH AVENUE
COLUMBUS, OHIO 43210-1174**

Catalog Description:

Vector operations; Jacobian and change of variables; div, grad and curl; Green's Stokes', and divergence theorems; applications.

Prerequisite:

C- or better in 2153, 2162.xx, 2173, or 2182H; or credit for 254.xx, 263.xx or 263.01H.

Exclusions:

Not open to students with credit for Math 4182H, 264H, 513 or 551.

Text:

Advanced Calculus, 5th edition, by Kaplan, published by Pearson, ISBN: 9780201799378

Topics List:

1. Vector operations, multiple integrals, line and surface integrals.
2. Vector operators: div, grad, and curl.
3. Jacobians and change of variables.
4. Green's Theorem, Stokes theorem.
5. Divergence Theorem.
6. Applications.

DEPARTMENT OF MATHEMATICS
THE OHIO STATE UNIVERSITY
231 WEST EIGHTEENTH AVENUE
COLUMBUS, OHIO 43210-1174

Catalog Description:

Introduction to analytic functions of a complex variable, integral theorems, power series, residues, conformal mapping.

Prerequisite:

C- or better in 2153, 2162.xx, 2173, 2182H, or 4182H; or credit for 254.xx, 263.xx, 263.01H, or 264H.

Exclusions:

Not open to students with credit for Math 5522H, 552 or 514.

Purpose:

This course provides a comprehensive introduction to complex analysis, emphasizing applications that are useful in science and engineering.

Text:

Complex Variables and Applications, 8th edition, by Brown & Churchill, published by McGraw-Hill, ISBN: 0073051942

Topics List:

Complex numbers, polar form (Ch. 1)
Analyticity, Cauchy-Riemann equations (Ch. 2)
Elementary functions (Ch. 3)
Cauchy integral theorem and consequences (Ch. 4)

Midterm 1

Power series (Ch. 5)
Residues and poles (Ch. 6)
Applications of residues (Ch. 7)
Mapping by elementary functions (Ch. 8)
Conformal mapping (Ch. 9)

Midterm 2

Applications of conformal mapping (Ch. 10)
Schwarz-Christoffel transformation (Ch. 11)
Poisson integral, Dirichlet problem (Ch. 12)

DEPARTMENT OF MATHEMATICS
THE OHIO STATE UNIVERSITY
231 WEST EIGHTEENTH AVENUE
COLUMBUS, OHIO 43210-1174

Catalog Description:

Systems of linear, first-order differential equations; existence and uniqueness theorems; numerical methods; qualitative theory (phase plane analysis, linearization, stability, limit cycles); and physical applications.

Prerequisite:

C- or better in 2153, 2162.xx, 2173, 2182H, or 4182H; or credit for 254.xx, 263, 263H, or 264H.

Text:

Nonlinear Dynamics and Chaos, Steven H. Strogatz, published by Westview Press, ISBN 9780738204536

Topics List:

1. One-dimensional flows: geometric way of thinking; fixed points and stability; population growth and other applications.
2. Bifurcations in one-dimensional flows: saddle-node, transcritical and pitchfork bifurcations; imperfect bifurcations.
3. Theory: existence; uniqueness; continuous dependence.
4. Phase planes: phase portraits; vector fields; nullclines; fixed points; stability; linearization.
5. Linear systems: classification of linear systems; what does the linear system say about the nonlinear system?
6. Limit cycles; introduction; Poincare-Bendixson theorem; conservative systems.
7. Bifurcations of two-dimensional flows; saddle-node, transcritical, and pitchfork bifurcations; Hopf bifurcation theorem.
8. XPPAUT: phase planes; bifurcations; applications.
9. Global bifurcations: homoclinic orbits; Poincare map; stability of periodic orbits.
10. Singular perturbations: Relaxation oscillator; averaging.
11. Applications: (e.g., Neurons).
12. One-dimensional maps: Logistic map.
13. Smale horseshoe: symbolic dynamics.
14. Applications.

DEPARTMENT OF MATHEMATICS
THE OHIO STATE UNIVERSITY
231 WEST EIGHTEENTH AVENUE
COLUMBUS, OHIO 43210-1174

Math 4556
Course Coordinator: D. Terman
2013-2014

Catalog Description:

First and second-order PDE's; existence and uniqueness, initial and boundary value problems, Fourier series; Green's functions; wave, heat and Laplace equations; nonlinear PDE's; applications.

Prerequisite:

C- or better in 2255, 2415, 4556, or 5520H; or credit for 255, 415.xx, or 521H.

Exclusions:

Not open to students with credit for Math 4512 or 512.

Text:

Partial Differential Equations, an Introduction, 2nd edition, Walter A. Strauss, published by Wiley, ISBN: 0471548685.

Topics List:

1. Definition of a PDE, linearity; solution of first-order linear (transport) equation; modeling with PDEs.
2. Well-posed problems, initial- and boundary conditions; second order equations; classification into types; the wave equation.
3. Causality and energy; diffusion equation; diffusion on the whole line.
4. Solution of the wave and diffusion equations on a half-line; diffusion and waves with sources.
5. Separation of variables for the wave equation, Dirichlet, Neumann and Robin conditions.
6. Fourier series; sine and cosine series; orthogonality and general Fourier series; completeness and convergence.
7. Midterm. Gibbs phenomenon.
8. Laplace's equation; maximum principle; rectangular coordinates.
9. Poisson's formula; Laplace's equation in circular coordinates.
10. Green's identities; maximum principle; Dirichlet principle; Green's second identity.
11. Green's functions; symmetry; half-space and sphere.
12. Wave equation in two and three dimensions; energy; causality; Huyghens' principle.
13. Rays and characteristics; relativistic geometry; sources; the diffusion equation.
14. The Schrödinger equation; the hydrogen atom.

Mathematics 4568
Au, Sp, Su

3 credits

Linear Algebra for
Engineering Graduate Students

Catalog Description:

Matrix algebra, vector spaces and linear maps, bases and dimension, eigenvalues and eigenvectors, applications.

Prerequisite:

C- or better in 2153, 2162.xx, 1172, 2182H, or 4182H; or credit for 254, 263.xx, 263.01H or 264H.

Exclusions:

Restricted to graduate students in engineering. No open to students with credit for 2568 (568), 5101 (601), 5520H (520H) or 572.

Text:

Introduction to Linear Algebra, 5th edition, by L.W. Johnson, R.D. Riess, and J.T. Arnold, published by Pearson, ISBN: 9780321628217.

Topics List:

Part I

- 1.1 Introduction to Matrices and Systems of linear equations
- 1.2 Echelon Form and Gaussian-Jordan Elimination
- 1.3 Consistent Systems of linear Equations
- 1.5 Matrix Operations
- 1.6 Algebraic Properties of Matrix operations
- 1.7 Linear Independence and Nonsingular Matrices
- 1.9 Matrix Inverses and Their Properties

Midterm I

Part II

- 2.1 Vectors in The Plane (Review only because it was done in 1152)
- 2.2 Vectors in Space (Review only because it was done in 1152)
- 2.3 The Dot Product and The Cross
- 3.1 Introduction
- 3.2 Vector Space Properties of \mathbb{R}^n
- 3.3 Examples of Subspaces
- 3.4 Bases for Subspaces
- 3.5 Dimension
- 5.2 Vector Spaces
- 5.3 Subspaces
- 5.4 Linear Independence, Bases, and Coordinates
- 3.6 Orthogonal Bases for Subspaces
- 3.7 Linear Transformation from \mathbb{R}^n to \mathbb{R}^m

Midterm 2

Part III

- 4.1 The Eigenvalue Problem for 2x2 Matrices
- 4.2 Determinants and the Eigenvalue Problem
- 4.4 Eigenvalues and Characteristic Polynomial
- 4.5 Eigenvectors and Eigenspaces
- 4.6 Complex Eigenvalues and Eigenvectors
- 4.7 Similarity Transformations and Diagonalization

Final

DEPARTMENT OF MATHEMATICS
THE OHIO STATE UNIVERSITY
231 WEST EIGHTEENTH AVENUE
COLUMBUS, OHIO 43210-1174

Mathematics 4573
Sp (odd years)

3 credits

Elementary Number Theory

Catalog Description:

Prime numbers, modular arithmetic, Diophantine equations, combinatorial analysis; introduction to concepts of abstract algebra.

Purpose:

To introduce students to some topics in number theory at the upper undergraduate level and make connections to other areas of mathematics, such as combinatorics and abstract algebra.

Prerequisite:

C- or better in 3345 or 4181H; or credit for 345 or 264H.

Exclusions:

Not open to students with credit for Math 5576H., 576H or 573.

Follow-up Courses:

4580-4581; or for students with an honors background, 5590H-5591H

Text:

An Introduction to the Theory of Numbers, 5th edition, by Niven, Zuckerman & Montgomery, published by TBS, ISBN: 9780471625469

Topics List:

1. Prime numbers and factorization
2. Congruences and modular arithmetic; the Euler phi-function $\phi(n)$.
3. Fermat's "Little" Theorem. Primitive roots.
4. Quadratic Reciprocity
5. Numerical Functions of number theory; multiplicative functions and Moebius inversion
6. Diophantine equations.
7. Number theory from an algebraic viewpoint; groups, rings and fields.
8. Possible additional topics: continued fractions, Pell's equation, and elliptic curves.

Mathematics 4575
Sp (even years)

3 credits

Combinatorial Mathematics

Catalog Description:

Classic puzzles of recreational mathematics; matching theory and graph theory; enumeration techniques; combinatorial analysis.

Prerequisite:

C- or better in 2568 or 5520H; credit for 568, 571, or 520H.

Exclusions:

Not open to students with credit for Math 5529H.

Topics List:

1. Counting principles.
2. Combinatorial identities.
3. Graphs.
4. Matchings.
5. Latin squares and finite projective planes.
6. Block designs.

Catalog Description:

Homogeneous and non-homogeneous difference equations of one or several variables, Markov chains, graph theory, network flows.

Prerequisite:

{C- or better in 2568 or 5520H; and C- or better in 4530, 5530H or Stat 420}; or {credit for 568, 571, or 520H; and credit for 530, 531H, or Stat 420}.

Exclusions: Not open to students with credit for 578.

Topics List:

1. Homogenous and non-homogeneous difference equations.
2. Application in finance, genetics, economics.
3. Matrix methods, nonlinear equations, stability, bifurcation, harvesting.
4. Application of Markov chains with absorbing and non-absorbing states, limiting behavior.
5. Graph theoretical algorithms, network flows, applications.

Catalog Description:

4580-4581 includes elementary number theory, group theory, vector spaces and linear transformation, and field theory.

Prerequisite:

{C- or better in 3345, and C- or better in 2568 or 5520H} or
{credit for 345; and credit for 568, 571, or 520H}.

Exclusions:

Not open to students with credit for 5590H or 591H.

Purpose:

Math 4580-4581 constitutes a two-semester sequence on abstract algebra, intended to familiarize students with the principal concepts, mode of thinking, and important theorems in this subject area. Considerable emphasis is placed on connections between this material and the traditional topics of high school mathematics - Euclidean geometry, polynomial equations, and trigonometry.

Math 4580 begins with a careful review of topics in elementary number theory. There is a study of number systems along with an introduction to the theory of polynomial equation. Groups are introduced in the context of geometrical symmetry and then applied to the constructability problem for regular polygons.

Text:

Notes on Abstract Algebra, by Ron Solomon (in-house notes).

Topics List:

1. Basic properties of the integers: division algorithm and Euclid's lemma
2. Basic properties of the rational numbers: fractions and decimals
3. Fermat's Little Theorem and the Euler ϕ -function
4. Review and Midterm 1
5. Basic properties of polynomials: division algorithm and Euclid's lemma
6. Complex numbers and polynomials of small degree
7. The cubic and quartic equations revisited
8. Cyclotomic polynomials
9. Review and Midterm 2
10. Isometries: Rotations, reflections, and translations
11. Congruence in geometry, and the definition of a group
12. Symmetry groups and dihedral groups
13. Constructible numbers
14. The Method of Monsieur Gauss

Catalog Description:

4580-4581 includes elementary number theory, group theory, vector spaces and linear transformation, and field theory.

Prerequisite:

C- or better in Math 4580; or credit for 581.

Exclusions:

Not open to students with credit for 5591H or 592H.

Purpose:

Math 4580-4581 constitutes a two-semester sequence on abstract algebra, intended to familiarize students with the principal concepts, mode of thinking, and important theorems in this subject area. Considerable emphasis is placed on connections between this material and the traditional topics of high school mathematics - Euclidean geometry, polynomial equations, and trigonometry. Math 4581 deepens the theory of groups and of polynomial equations, culminating in Galois' theory of equations and the classification of finite symmetry groups in R^3 .

Text:

Notes on Abstract Algebra, by Ron Solomon (in-house notes)

Topics List:

1. Permutation groups, orbits, and Lagrange's Theorem
2. The Orbit Counting Formula
3. Imaginaries and Galois fields
4. Gaussian integers and Fermat's two squares theorem
5. Review and Midterm 1
6. Symmetric polynomials and the Fundamental Theorem of Algebra
7. Nonconstructibility and a Lagrange Theorem for fields
8. Galois' Theory of Equations
9. The Galois Correspondence
10. Review and Midterm 2
11. The isometry group of R^2
12. Linear algebra in R^3
13. The Platonic solids and their symmetries
14. The finite subgroups of $SO(3)$

Mathematics 5520H
Au

5 credits

**Honors Linear Algebra and
Differential Equations**

Catalog Description:

Linear transformations and matrices, spectral theorem, ordinary differential equations, existence and uniqueness theorems, phase space, stability, oscillations.

Prerequisite:

C or better in 4182H or in both 2182H and 3345; or C or better in 264H or in both 263H and 345; or permission of department.

Text:

Linear Algebra: An Introductory Approach, revised 4th edition, by Curtis, published by Springer, ISBN: 9780387909929

Introduction to Ordinary Differential Equations, by Coddington, published by Dover, ISBN: 9780486659428

Topics List:

1. Vector spaces and linear transformations.
2. Systems of equations, determinants.
3. Spectral theorem.
4. Ordinary, linear and nonlinear differential equations.
5. Existence and uniqueness theorems.
6. Phase space, stability, and periodic points.

**DEPARTMENT OF MATHEMATICS
THE OHIO STATE UNIVERSITY
231 WEST EIGHTEENTH AVENUE
COLUMBUS, OHIO 43210-1174**

Mathematics 5522H
Sp

5 credits

Honors Complex Analysis

Catalog Description:

Theoretical treatment of complex analysis.

Prerequisite:

C or better in 5520H, credit for 521H, or permission of department.

Topics List:

1. Analytic functions.
2. Residue calculus.
3. Series representations.
4. Conformal mappings.
5. Laplace transform.
6. Applications to number theory, geometry, physics.

**DEPARTMENT OF MATHEMATICS
THE OHIO STATE UNIVERSITY
231 WEST EIGHTEENTH AVENUE
COLUMBUS, OHIO 43210-1174**

Mathematics 5529H
Au, of even numbered years

5 credits

Honors Combinatorics

Catalog Description:

Techniques of combinatorial mathematics; connections with geometry, algebra, analysis, and probability.

Prerequisite:

C or better in 4182H, or in both 2182H and 3345; or credit for 264H, or for both 263H and 345; or permission of department.

Text:

Discrete Mathematics, by Lovasz, Pelican & Vestergombi, published by Springer,
ISBN: 9780387955858

Proofs from the Book, 4th edition, by Aigner, Ziegler & Hofmann, published by Springer,
ISBN: 9783642008559

Topics List:

1. Counting principles.
2. Generating functions.
3. Finite fields and applications.
4. Theory of partitions.
5. Famous graphs.
6. Ramsey theory.
7. Permutation groups.

**DEPARTMENT OF MATHEMATICS
THE OHIO STATE UNIVERSITY
231 WEST EIGHTEENTH AVENUE
COLUMBUS, OHIO 43210-1174**

Mathematics 5530H
Sp, of odd numbered years

5 credits

Honors Probability

Catalog Description:

Theoretical treatment of probability, with applications within and outside mathematics.

Prerequisite:

C or better in 5529H, or permission of department.

Topics List:

1. Historical origins of probability.
2. Diverse ways of sampling, allocation, models.
3. Random variables, expectation, moments.
4. Important distributions.
5. Limit theorems: law of large numbers, central limit theorem.
6. Random walks and Markov chains.
7. Statistical independence in analysis and number theory.

**DEPARTMENT OF MATHEMATICS
THE OHIO STATE UNIVERSITY
231 WEST EIGHTEENTH AVENUE
COLUMBUS, OHIO 43210-1174**

Mathematics 5540H
Sp, of even numbered years

5 credits

Honors Differential Geometry

Catalog Description:

Geometry of curves and surfaces in 3-dimensional space, curvature, geodesics, Gauss-Bonnet Theorem, Riemannian metrics.

Prerequisite:

C or better in 5520H, or in both 2182H and 2568; or credit for 520H, or in both 263.01H and 568; or permission of department.

Topics List:

1. Geometry of curves; Frenet-Serret equations.
2. Curvature of surfaces, First Fundamental Form, Gauss's Theorema Egregium.
3. Geodesics, exponential map.
4. Isometries, conformal mappings; mapmaking.
5. Gauss-Bonnet Theorem.
6. Riemannian metrics, non-Euclidean geometry.

**DEPARTMENT OF MATHEMATICS
THE OHIO STATE UNIVERSITY
231 WEST EIGHTEENTH AVENUE
COLUMBUS, OHIO 43210-1174**

Mathematics 5576H
Au, of odd numbered years

5 credits

Honors Number Theory

Catalog Description:

Elementary analytic and algebraic number theory, tracing its unifying role in the development of mathematics through history.

Prerequisite:

C or better in 4182H, or in both 2182H and 3345; or credit for 264H, or for both 263H and 345; or permission of department.

Text:

An Introduction to the Theory of Numbers, 6th edition, by Hardy, Wright, Heath & Brown, published by Oxford, ISBN: 9780199219865.

Problem-Solving & Selected Topics in Number Theory: In the Spirit of the Mathematical Olympiads, by Rassias, published by Springer, ISBN: 9781441904942.

Topics List:

1. Ancient Egyptian and Mesopotamian mathematics, the Greek tradition.
2. Famous irrationalities.
3. Continued fractions and applications.
4. Prime numbers and their asymptotic properties.
5. Quadratic reciprocity.
6. p-adic numbers, Ostrowski's Theorem.
7. Fermat's last theorem: a glimpse into modern developments.

DEPARTMENT OF MATHEMATICS
THE OHIO STATE UNIVERSITY
231 WEST EIGHTEENTH AVENUE
COLUMBUS, OHIO 43210-1174

Catalog Description:

5590-5591 includes elementary number theory, group theory, ring theory, abstract linear algebra, field theory, and Galois theory.

Prerequisite:

C or better in 5520H or in 520H, or permission of department.

Text:

Abstract Algebra, 3rd edition, by Dummit & Foote, published by Wiley, ISBN: 9780471433349

Topics List:

1. Groups and homomorphisms, cosets and Lagrange's Theorem.
2. Group actions and Sylow's Theorems.
3. Normal subgroups, factor groups, direct and indirect products.
4. Rings, homomorphisms, ideals, and factor rings.
5. Principal ideal domains, unique factorization domains.
6. Polynomial rings.

DEPARTMENT OF MATHEMATICS
THE OHIO STATE UNIVERSITY
231 WEST EIGHTEENTH AVENUE
COLUMBUS, OHIO 43210-1174

Mathematics 5591H
Sp

5 credits

Honors Abstract Algebra II

Catalog Description:

Continuation of Math 5590H.

Prerequisite:

C or better in 5590H or in 591H, or permission of department.

Topics List:

1. Modules and vector spaces.
2. Modules over a PID, applications to linear algebra.
3. Finite extensions of fields, minimal polynomials, degree, algebraic numbers.
4. Galois theory and its applications.

**DEPARTMENT OF MATHEMATICS
THE OHIO STATE UNIVERSITY
231 WEST EIGHTEENTH AVENUE
COLUMBUS, OHIO 43210-1174**

Catalog Description:

This course sequence introduces students to the mathematical theory of contingencies. Includes material from examinations by the Society of Actuaries and the Casualty Actuarial Society.

Prerequisite:

C- or better in 3618 ^{B- ?} and C- or better in 4530, 5530H, or Stat 4201; or credit for 530, 531H, or Stat 420; or permission of department.

Exclusions:

Open only to actuarial science majors.

Text:

Actuarial Mathematics for Life Contingent Risks, by Dickson, Hardy & Waters, published by Cambridge, ISBN: 9780521118255

Topics List:

1. Survival distributions.
2. Individual risk models.
3. Life tables.
4. Topics from life insurance.
5. Life annuities.
6. Benefit premiums.

DEPARTMENT OF MATHEMATICS
THE OHIO STATE UNIVERSITY
231 WEST EIGHTEENTH AVENUE
COLUMBUS, OHIO 43210-1174

Catalog Description: 630
Continuation of Math 5630 or ~~530~~.

Prerequisite:
C- or better in Math 5630, or credit for 630.

Exclusions:
Open only to actuarial science majors, and to MMS students specializing in Financial Math.

Text:
Actuarial Mathematics for Life Contingent Risks, by Dickson, Hardy & Waters, published by Cambridge, ISBN: 9780521118255.

- Topics List:**
1. Benefit reserve.
 2. Multiple life functions.
 3. Multiple decrement models.
 4. Random and deterministic survivorship group.
 5. Valuation of pension plans.
 6. Applications.

DEPARTMENT OF MATHEMATICS
THE OHIO STATE UNIVERSITY
231 WEST EIGHTEENTH AVENUE
COLUMBUS, OHIO 43210-1174

Catalog Description:

Introduction to the evaluation of options, futures, and other derivatives, interest models and risk management techniques. Includes material from examinations by the Society of Actuaries and the Casualty Actuarial Society.

Prerequisite:

{C- or better in 3618, or credit for 618, or permission of department} –and– {C- or better in 4530 or Stat 4201 or credit for 530 or Stat 420}.

Exclusions:

Restricted to actuarial science majors, math majors, and students with graduate standing.

Text:

Derivatives Markets, 2nd edition, by McDonald, published by Addison-Wesley,
ISBN: 9780321280305

Topics List:

1. Option relationships.
2. Binomial option pricing.
3. Black-Scholes formula.
4. Market making and delta hedging.
5. Exotic options.
6. Brownian motions and Ito's Lemma.
7. Interest rate models.

**DEPARTMENT OF MATHEMATICS
THE OHIO STATE UNIVERSITY
231 WEST EIGHTEENTH AVENUE
COLUMBUS, OHIO 43210-1174**

Catalog Description:

5633-5634 introduces students to the construction and evaluation of actuarial models, with topics covered by examinations of the Society of Actuaries and the Casualty Actuarial Society.

Prerequisite:

{C- or better in 4530, 5530H, Stat 4201, or credit for 530, 531H, or Stat 420}; and {C- or better in Stat 4202 or credit for Stat 421}.

Exclusions:

Open only to actuarial science majors and to MMS students specializing in Financial Math.

Text:

Loss Models: From Data to Decisions, 4th edition, by Klugman, Panjer and Willmot, published by Wiley, ISBN: 9781118315323.

Topics List:

1. Measures of risk.
2. Characteristics of actuarial models.
3. Severity models.
4. Frequency models.
5. Aggregate loss models.

DEPARTMENT OF MATHEMATICS
THE OHIO STATE UNIVERSITY
231 WEST EIGHTEENTH AVENUE
COLUMBUS, OHIO 43210-1174

Mathematics 5634
Sp

3 credits

Loss Models II

Catalog Description:

Continuation of 5633.

Prerequisite:

C- or better in 5633.

Exclusions:

Open only to actuarial science majors and to MMS students specializing in Financial Math.

Topics List:

1. Estimation of data.
2. Parameter estimation.
3. Model selection.
4. Simulation.
5. Credibility.

**DEPARTMENT OF MATHEMATICS
THE OHIO STATE UNIVERSITY
231 WEST EIGHTEENTH AVENUE
COLUMBUS, OHIO 43210-1174**